

# Fire detection and fire alarm systems —

## Part 11: Manual call points

The European Standard EN 54-11:2001, with the incorporation of amendment A1:2005, has the status of a British Standard

ICS 13.220.20; 13.320

## National foreword

This British Standard is the official English language version of EN 54-11:2001, including amendment A1:2005. It supersedes BS 5839-2:1983 which is withdrawn. It is one of a series of standards for fire detection and fire alarm systems (see BS EN 54-1 for a full list of current and proposed standards).

The UK participation in its preparation was entrusted by Technical Committee FSH/12, Fire detection and fire alarm systems, to Subcommittee FSH/12/2, Fire detectors, which has the responsibility to:

- aid enquirers to understand the text;
- present to the responsible international/European committee any enquiries on the interpretation, or proposals for change, and keep UK interests informed;
- monitor related international and European developments and promulgate them in the UK.

A list of organizations represented on this committee can be obtained on request to its secretary.

### Cross-references

The British Standards which implement international or European publications referred to in this document may be found in the *BSI Catalogue* under the section entitled “International Standards Correspondence Index”, or by using the “Search” facility of the *BSI Electronic Catalogue* or of British Standards Online.

This publication does not purport to include all the necessary provisions of a contract. Users are responsible for its correct application.

**Compliance with a British Standard does not of itself confer immunity from legal obligations.**

### Summary of pages

This document comprises a front cover, an inside front cover, the EN title page, pages 2 to 48, an inside back cover and a back cover.

The BSI copyright notice displayed in this document indicates when the document was last issued.

This British Standard, having been prepared under the direction of the Health and Environment Sector Committee, was published under the authority of the Standards Committee and comes into effect on 15 July 2001

© BSI 2006

### Amendments issued since publication

Amd. No.	Date	Comments
16126	30 June 2006	Addition of Annex ZA and Bibliography
16487 Corrigendum No. 1	30 June 2006	Correction to formatting errors at printing stage

ICS 13.220.20

English version

## Fire detection and fire alarm systems — Part 11: Manual call points

(including amendment A1:2005)

Systèmes de détection automatique d'incendie —  
Partie 11: Déclencheurs manuels d'alarme  
(inclut l'amendement A1:2005)

Brandmeldeanlagen — Teil 11: Handfeuermelder  
(enthält Änderung A1:2005)

This European Standard was approved by CEN on 19 February 2001; amendment A1:2005 was approved by CEN on 14 October 2005.

CEN members are bound to comply with the CEN/CENELEC Internal Regulations which stipulate the conditions for giving this European Standard the status of a national standard without any alteration. Up-to-date lists and bibliographical references concerning such national standards may be obtained on application to the Management Centre or to any CEN member.

This European Standard exists in three official versions (English, French, German). A version in any other language made by translation under the responsibility of a CEN member into its own language and notified to the Management Centre has the same status as the official versions.

CEN members are the national standards bodies of Austria, Belgium, Cyprus, Czech Republic, Denmark, Estonia, Finland, France, Germany, Greece, Hungary, Iceland, Ireland, Italy, Latvia, Lithuania, Luxembourg, Malta, Netherlands, Norway, Poland, Portugal, Slovakia, Slovenia, Spain, Sweden, Switzerland and United Kingdom.



EUROPEAN COMMITTEE FOR STANDARDIZATION  
COMITÉ EUROPÉEN DE NORMALISATION  
EUROPÄISCHES KOMITEE FÜR NORMUNG

**Management Centre: rue de Stassart, 36 B-1050 Brussels**

## Contents

	Page
<b>Foreword</b> .....	<b>3</b>
<b>Introduction</b> .....	<b>4</b>
<b>1 Scope</b> .....	<b>4</b>
<b>2 Normative references</b> .....	<b>5</b>
<b>3 Terms and definitions</b> .....	<b>6</b>
<b>4 Requirements</b> .....	<b>7</b>
4.1 Compliance .....	7
4.2 Marking and data .....	7
4.3 Frangible element .....	8
4.4 Indicators for alarm condition .....	9
4.5 Reset facility .....	9
4.6 Test facility .....	9
4.7 Construction and design .....	9
4.8 Additional requirements for software controlled manual call points .....	14
<b>5 Tests</b> .....	<b>15</b>
5.1 General .....	15
5.2 Operational performance test .....	17
5.3 Function test .....	19
5.4 Test facility test (operational) .....	19
5.5 Reliability test (endurance) .....	20
5.6 Variation of supply parameters .....	20
5.7 Dry heat (operational) .....	21
5.8 Dry heat (endurance) .....	22
5.9 Cold (operational) .....	23
5.10 Damp heat, cyclic (operational) .....	24
5.11 Damp heat, cyclic (endurance) .....	25
5.12 Damp heat, steady state (endurance) .....	25
5.13 SO <sub>2</sub> corrosion (endurance) .....	26
5.14 Shock (operational) .....	27
5.15 Impact (operational) .....	28
5.16 Vibration, sinusoidal (operational) .....	29
5.17 Vibration, sinusoidal (endurance) .....	30
5.18 Electromagnetic compatibility (EMC) (operational) .....	31
5.19 Enclosure protection .....	32
<b>Annex A (normative) Test apparatus for test for operation</b> .....	<b>34</b>
<b>Annex B (informative) Test apparatus for test for non-operation</b> .....	<b>35</b>
<b>Annex C (informative) Test apparatus for the impact test</b> .....	<b>36</b>
<b>Annex ZA (informative) Clauses addressing the provisions of the EU Construction Products Directive 89/106/EEC</b> .....	<b>40</b>
<b>Bibliography</b> .....	<b>48</b>

## Foreword

This European Standard has been prepared by Technical Committee CEN/TC 72, Fire detection and fire alarm systems, the Secretariat of which is held by BSI.

This European Standard shall be given the status of a national standard, either by publication of an identical text or by endorsement, at the latest by November 2001, and conflicting national standards shall be withdrawn at the latest by November 2003. For products which have complied with the relevant national standard before the date of withdrawal (dow), as shown by the manufacturer or by a certification body, this previous standard may continue to apply for production until November 2006.

This European Standard has been prepared under a mandate given to CEN by the European Commission and the European Free Trade Association, and supports essential requirements of EU Directive(s).

This standard has been prepared in co-operation with the CEA (Comité Européen des Assurances) and with EURALARM (Association of European Manufacturers of Fire and Intruder Alarm Systems).

Information on the relationship between this European Standard and other standards of the EN 54 series is given in annex A of EN 54-1:1996.

According to the CEN/CENELEC Internal Regulations, the national standards organizations of the following countries are bound to implement this European Standard: Austria, Belgium, Czech Republic, Denmark, Finland, France, Germany, Greece, Iceland, Ireland, Italy, Luxembourg, Netherlands, Norway, Portugal, Spain, Sweden, Switzerland and the United Kingdom.

## Foreword to amendment A1

This document (EN 54-11:2001/A1:2005) has been prepared by Technical Committee CEN/TC72 "Fire detection and fire alarm systems", the secretariat of which is held by BSI.

This Amendment to the European Standard EN 54-11:2001 shall be given the status of a national standard, either by publication of an identical text or by endorsement, at the latest by May 2006, and conflicting national standards shall be withdrawn at the latest by August 2007.

This Amendment to EN 54-11:2001 has been prepared under a mandate given to CEN by the European Commission and the European Free Trade Association and supports the essential requirements of the EU Construction Products Directive (89/106/EEC).

For relationship with EU Directive(s), see informative Annex ZA, which is an integral part of this document.

According to the CEN/CENELEC Internal Regulations, the national standards organizations of the following countries are bound to implement this European Standard: Austria, Belgium, Cyprus, Czech Republic, Denmark, Estonia, Finland, France, Germany, Greece, Hungary, Iceland, Ireland, Italy, Latvia, Lithuania, Luxembourg, Malta, Netherlands, Norway, Poland, Portugal, Slovakia, Slovenia, Spain, Sweden, Switzerland and United Kingdom.

## Introduction

This European Standard has been drafted on the basis of appearance and functions which should be provided on all manual call points for use in fire detection and fire alarm systems. The colours, dimensions, shapes and methods of operation are based on recognized operating principles which give confidence and recognition to the user when operated in genuine fire alarm situations.

It is important for manual call points to be recognizable and simple to use, without the need to read elaborate instructions so that anyone discovering a fire is able to use the manual call point without previous familiarity with it.

The purpose of a manual call point is to enable a person discovering a fire to initiate the operation of a fire alarm system so that appropriate measures can be taken.

The intention of this European Standard is to specify requirements for operation and reliability. The methods of operation of the manual call points covered are as follows:

- Type A: direct operation (single action).
- Type B: indirect operation (double action).

Both types require the breaking or the visible displacement by change of the position of a frangible element forming part of the front face, which is considered to be the most suitable method for general application and which acts as a deterrent to the misuse of the device.

Importance has been placed on identifying the manual call point, the method by which it is activated and an indication to the user that the initiation of an alarm has been given.

The resulting standard takes into account national variances in custom and practice and language in bringing together common elements that contribute towards a standard device for use throughout Europe.

## 1 Scope

This European Standard specifies the requirements and methods of test for manual call points in fire detection and fire alarm systems in and around buildings. It takes into account indoor and outdoor conditions, the appearance and operation of the manual call points for type A “direct operation” and type B “indirect operation” and covers those which are simple mechanical switches, those which are fitted with simple electronic components (e.g. resistors, diodes) and those which contain active electronic components and which work with the control panels for signalling and identifying, for example, an address or location.

This European Standard does not cover manual call points for special applications, for example manual call points that are intrinsically safe or for use in hazardous conditions, if such applications require additional or other requirements or tests than those given in this standard.

## 2 Normative references

This European Standard incorporates, by dated or undated reference, provisions from other publications. These normative references are cited at the appropriate places in the text and the publications are listed hereafter. For dated references, subsequent amendments to or revisions of any of these publications apply to this European Standard only when incorporated in it by amendment or revision. For undated references the latest edition of the publication referred to applies (including amendments).

ISO/IEC Publication	Year	Title	EN/HD	Year
—	—	<i>Fire detection and fire alarm systems — Part 1: Introduction.</i>	EN 54-1	1996
—	—	<i>Fire detection and fire alarm systems — Part 2: Control and indicating equipment.</i>	EN 54-2	1997
—	—	<i>Safety of machinery — Ergonomics requirements for the design of displays and control actuators — Part 3: Control actuators.</i>	EN 894-3	2000
—	—	<i>Alarm systems — Part 4: Electromagnetic compatibility — Product family standard: Immunity requirements for components of fire, intruder and social alarm systems.</i>	EN 50130-4	1995
IEC 60068-1	1988	<i>Environmental testing — Part 1: General and guidance (IEC 60068-1:1988/Corrigendum 1988/A1:1992).</i>	EN 60068-1	1994
IEC 60068-2-1	1990	<i>Environmental testing — Part 2: Tests — Tests A: Cold (IEC 60068-2-1:1990).</i>	EN 60068-2-1	1993
IEC 60068-2-1/A1	1993	<i>Environmental testing — Part 2: Tests — Tests A: Cold (IEC 60068-2-1/A1:1993).</i>	EN 60068-2-1/A1	1993
IEC 60068-2-1/A2	1994	<i>Environmental testing — Part 2: Tests — Tests A: Cold (IEC 60068-2-1/A2:1994).</i>	EN 60068-2-1/A2	1994
IEC 60068-2-2	1974	<i>Basic environmental testing procedures — Part 2: Tests — Test B: Dry heat (IEC 60068-2-2:1974/IEC 68-2-2A:1976).</i>	EN 60068-2-2	1993
IEC 60068-2-2/A1	1993	<i>Basic environmental testing procedures — Part 2: Tests — Test B: Dry heat (IEC 60068-2-2/A1:1993).</i>	EN 60068-2-2/A1	1993
IEC 60068-2-2/A2	1994	<i>Basic environmental testing procedures — Part 2: Tests — Test B: Dry heat (IEC 60068-2-2/A2:1994).</i>	EN 60068-2-2/A2	1994
IEC 60068-2-3	1969	<i>Basic environmental testing procedures — Part 2: Tests — Test Ca: Damp heat, steady state.</i>	HD 323.2.3 S2	1987
IEC 60068-2-6	1995	<i>Environmental testing — Part 2: Tests — Test Fc: Vibration (sinusoidal) (IEC 60068-2-6:1995/Corrigendum 1995).</i>	EN 60068-2-6	1995
IEC 60068-2-18	1989	<i>Environmental testing — Part 2: Tests — Test R and guidance: Water.</i>	—	—
IEC 60068-2-18/A1	1993	<i>Environmental testing — Part 2: Tests — Test R and guidance: Water (Amendment 1).</i>	—	—
IEC 60068-2-27	1987	<i>Basic environmental testing procedures — Part 2: Tests — Test Ea and guidance: Shock (IEC 60068-2-27:1987).</i>	EN 60068-2-27	1993

IEC 60068-2-30	1980	<i>Basic environmental testing procedures — Part 2: Tests — Test Db and guidance: Damp heat, cyclic (12 + 12-hour cycle).</i>	HD 323.2.30 S3	1988
IEC 60068-2-30/A1	1985	<i>Basic environmental testing procedures — Part 2: Tests — Test Db and guidance: Damp heat, cyclic (12 + 12-hour cycle).</i>	—	—
IEC 60068-2-42	1982	<i>Basic environmental testing procedures — Part 2: Tests — Test Kc: Sulphur dioxide test for contacts and connections.</i>	—	—
IEC 60068-2-56	1988	<i>Environmental testing — Part 2: Tests — Test Cb: Damp heat, steady state, primarily for equipment.</i>	HD 323.2.56 S1	1990
ISO 209-1	1989	<i>Wrought aluminium and aluminium alloys — Chemical composition and forms of products — Part 1: Chemical composition.</i>	—	—
ISO 3098-0	1997	<i>Technical product documentation — Lettering — Part 0: General requirements.</i>	EN ISO 3098-0	1997
ISO 3864	1984	<i>Safety colours and safety signs.</i>	—	—

### 3 Terms and definitions

For the purposes of this European Standard, the terms and definitions given in EN 54-1:1996 apply together with the following.

#### 3.1

##### **alarm condition**

the condition of the manual call point after the operating element has been activated

#### 3.2

##### **frangible element**

a component which is glass or has the appearance of glass and which after receiving a blow or pressure as instructed, is physically broken or is visibly displaced by change of position and remains in that condition until replaced or reset

NOTE The frangible element is intended to give protection against unintentional operation and to be a deterrent against misuse. The visible displacement of the frangible element is accepted as apparent breaking.

##### 3.2.1

##### **non-resettable frangible element**

a frangible element that needs to be replaced after the activation of the manual call point, in order for the manual call point to be able to return to the normal condition

##### 3.2.2

##### **resettable frangible element**

a frangible element that can be returned to its original position without replacement, in order for the manual call point to be able to return to the normal condition

#### 3.3

##### **front face**

the area within the outline of the front view of the manual call point excluding the area of the operating face

NOTE See Figures 1 and 2, item 1.



### 3.4

#### **manual call point**

a component of a fire detection and fire alarm system which is used for the manual initiation of an alarm [EN 54-1:1996]

Manual call points are divided into two types depending on the method of operation:

#### 3.4.1

##### **type A: direct operation**

a manual call point in which the change to the alarm condition is automatic (i.e. without the need for further manual action) when the frangible element is broken or displaced

#### 3.4.2

##### **type B: indirect operation**

a manual call point in which the change to the alarm condition requires a separate manual operation of the operating element by the user after the frangible element is broken or displaced

### 3.5

#### **normal condition**

the condition in which the frangible element is undamaged and the manual call point is operating without giving an alarm or fault signal

### 3.6

#### **operating element**

mechanical and electrical switching element; the part of the manual call point which initiates the alarm signal when operated

### 3.7

#### **operating face**

that area of the manual call point which may be the visible part of the frangible element or the visible area behind it

NOTE See Figures 1 and 2, item 2.

### 3.8

#### **special tool**

a device not normally carried by the public (e.g. a key), normally provided by the manufacturer and which is used for replacing or resetting the frangible element

NOTE It is intended to deter unauthorized access to the manual call point, while being available on site either at a defined location or from a "responsible person" familiar with and having knowledge of the system.

## 4 Requirements

### 4.1 Compliance

In order to comply with this standard the manual call point shall meet the requirements of this clause which shall be verified by visual inspection or engineering assessment, shall be tested as described in clause 5 and shall meet the requirements of the tests.

### 4.2 Marking and data

#### 4.2.1 Marking

Each manual call point shall be permanently marked with the following information:

- a) the number of this standard (i.e. EN 54-11);
- b) the name or trademark of the manufacturer or supplier;
- c) the model designation (type A or type B);

- d) environment category (indoor/outdoor, special environmental conditions);
- e) the wiring terminal designations;
- f) any mark(s) or code(s) (e.g. serial number or batch code) by which the manufacturer can identify, at least, the date or batch and place of manufacture, and the version number(s) of any software contained within the manual call point.

Where any marking on the manual call point uses symbols or abbreviations not in common use, then these shall be explained in the data supplied with the device.

The marking shall be visible during installation of the manual call point and shall be accessible during maintenance.

The markings shall not be placed on screws or other easily removable parts.

#### **4.2.2 Data**

Manual call points shall either be supplied with sufficient technical, installation and maintenance data to enable their correct installation and operation or, if all of these data are not supplied with each manual call point, reference to the appropriate data sheet shall be given on or with each manual call point.

To enable correct operation of the manual call points, these data shall describe the requirements for the correct processing of the signals from the manual call point. This may be in the form of a full technical specification of these signals, a reference to the appropriate signalling protocol or a reference to suitable types of control and indicating equipment, etc.

NOTE Additional information may be required by organizations certifying that manual call points produced by a manufacturer conform to the requirements of this standard.

### **4.3 Frangible element**

#### **4.3.1 Normal condition**

The normal condition shall be easily recognizable by the appearance of the operating face as detailed in 4.7. The frangible element shall be flat and shall not be broken, deformed or displaced.

#### **4.3.2 Alarm condition**

Transfer from the normal condition to the alarm condition shall be achieved by the following and shall be easily recognizable by the change in the appearance of the operating face:

- a) For type A manual call points:
  - 1) breaking the frangible element; or
  - 2) displacing the frangible element as a result of the breaking; or
  - 3) displacing the frangible element without breaking, together with changing the appearance of the operating face.
- b) For type B manual call points:
  - 1) breaking and/or displacement of the frangible element as described in 4.3.2 a) to give access to the operating element; and
  - 2) manual activation of the operating element.

In addition, for type B manual call points, it shall be possible to see that the operating element is in the activated position and it shall not be possible to activate the operating element without breaking or displacing the frangible element [see 4.3.2 b)] or without the use of a special tool (see 4.6).

#### 4.4 Indicators for alarm condition

The alarm condition shall be indicated by:

- a) for type A: the condition of the frangible element as specified in 4.3;
- b) for type B: the frangible element as described in 4.3 together with an identifiable activated position of the operating element.

The alarm condition may be additionally indicated visually by other means, for example using lamps or light-emitting diodes (LEDs).

If an additional visual indicator is provided, it shall be positioned within the operating face or within the front face of the manual call point. The visual indicator shall be red, shall identify the manual call point which released an alarm, until the alarm condition is reset, and shall be visible from a distance of 2 m directly in front of the manual call point in an ambient light intensity up to 500 lx. Where other conditions of the manual call point may be visually indicated, they shall be clearly distinguishable from the alarm indication, except when the manual call point is switched into a service mode.

#### 4.5 Reset facility

It shall only be possible to reset the manual call point after operation by means of a special tool as follows:

- a) for non-resettable frangible elements, by inserting a new element;
- b) for resettable frangible elements, by resetting the frangible element.

In addition, for type B manual call points, it shall only be possible to return the operating element to its normal condition by means of a special tool.

#### 4.6 Test facility

The manual call point shall be equipped with a facility to carry out routine testing when installed. The operation of this test facility shall:

- a) simulate the alarm condition by activating the operating element without breaking the frangible element; and
- b) allow the manual call point to be reset without breaking the frangible element.

The operation of the test facility shall only be possible using a special tool.

#### 4.7 Construction and design

##### 4.7.1 Safety aspects

When operating the frangible element, injury to the operator shall not occur.

For type B manual call points the actuation force of the operating element shall meet the requirements of EN 894-3:2000.

Corners and edges of the manual call points shall be rounded to reduce the possibility of injury, but the radius of curvature shall not exceed 0,05 *a* (see Table 1).

##### 4.7.2 Shape, dimensions and colours

###### 4.7.2.1 Shape

The front face of the manual call point shall be approximately square in accordance with Table 1.

The operating face shall either be square (see Figure 1) or rectangular (see Figure 2).

The operating face in accordance with Table 1, Figure 1 and Figure 2:

- a) shall be central about the vertical centre line of the front face; and
- b) may be designed to have a vertical offset about the horizontal centre line of the front face.

The operating face shall be level with with or recessed into the front face; it shall not project beyond the front face.

#### 4.7.2.2 Dimensions

The dimensions of the front face and of the operating face shall be within the limits shown in Figure 1, Figure 2 and Table 1. A tolerance of  $\pm 5\%$  may be applied where not otherwise specified.

The manual call point shall be designed so that it is capable of being mounted, in accordance with the manufacturer's instructions, with the front face at least 15 mm proud of the surrounding surface.

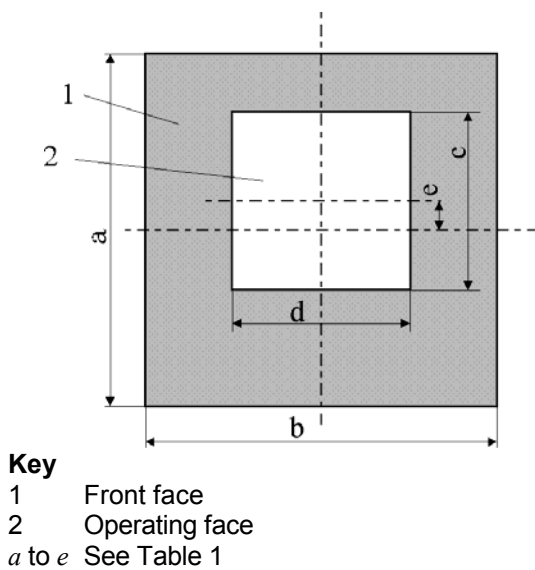

**Figure 1 — Manual call point with a square operating face**

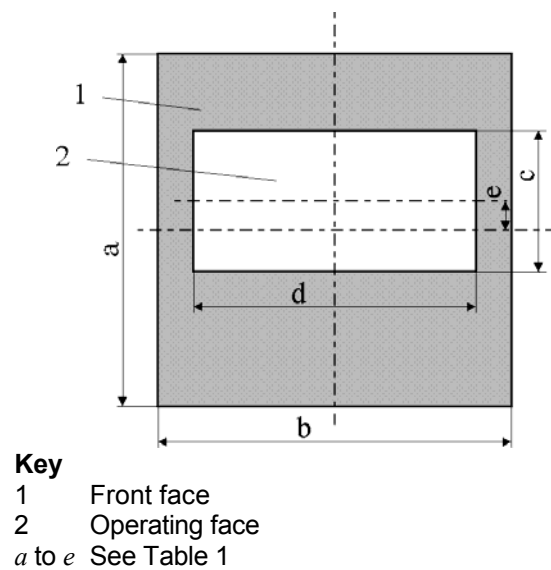

**Figure 2 — Manual call point with a rectangular operating face**

**Table 1 — Dimensions of manual call points**

Dimension	Letter in Figure 1 or Figure 2	Manual call point with	
		Square operating face	Rectangular operating face
Height of front face	<i>a</i>	$85 \text{ mm} \leq a \leq 135 \text{ mm}$	$85 \text{ mm} \leq a \leq 135 \text{ mm}$
Width of front face	<i>b</i>	$85 \text{ mm} \leq b \leq 135 \text{ mm}$	$85 \text{ mm} \leq b \leq 135 \text{ mm}$
Ratio of width to height of the front face	<i>b/a</i>	$0,95 \leq b/a \leq 1,05$	$0,95 \leq b/a \leq 1,05$
Height of operating face	<i>c</i>	$0,5 a \pm 5 \text{ mm}$	$0,4 a \pm 5 \text{ mm}$
Width of operating face	<i>d</i>	$0,5 a \pm 5 \text{ mm}$	$0,8 a \pm 5 \text{ mm}$
Ratio of width to height of the operating face	<i>d/c</i>	$0,95 \leq d/c \leq 1,05$	$1,9 \leq d/c \leq 2,1$
Maximum vertical offset of the operating face	<i>e</i>	$\pm 0,1 a$	$\pm 0,1 a$

### 4.7.2.3 Colours

The colour of the visible surface area of the manual call point when mounted in accordance with 5.1.3 shall be red, except for:

- a) the operating face;
- b) the symbols and lettering on the front face specified in 4.7.3.2;
- c) the special tool access, cable entry holes and screws.

The colour of the operating face other than symbols and lettering specified in 4.7.3.3 shall be white.

The colour of the visible part of the operating element (type B manual call point) shall be black.

NOTE Suitable red, white and black colours are specified in ISO 3864.

## 4.7.3 Symbols and lettering

### 4.7.3.1 General

The manual call point shall be marked, with the appropriate symbols shown in Figure 3, as specified in 4.7.3.2 and 4.7.3.3. Examples of the arrangement of symbols on type A and type B manual call points are given in Figures 4 and 5 respectively.

### 4.7.3.2 Symbols and lettering on the front face

**4.7.3.2.1** On the front face above the operating face and central to the vertical centre line shall be the symbol in accordance with Figure 3 a). This symbol may be supplemented with the word "FIRE" or equivalent words in the national language. This combination shall be on the front face and above the operating face and central to the vertical centre line. The height of the symbol shall be at least  $0,15 a$  and the height of the lettering shall not exceed the height of the symbol. The lettering shall be in accordance with ISO 3098-0:1997, "lettering type B, vertical (V)". Symbols and lettering shall be white in accordance with ISO 3864:1984.

**4.7.3.2.2** Markings other than specified in 4.7.3.2.1 (such as company logo or contact address) shall be restricted to the area of the front face below the horizontal centre line of the operating face. The total area for this marking other than red shall not be greater than 5 % of the area of the front face.

### 4.7.3.3 Symbols and lettering on the operating face

**4.7.3.3.1** The operating face of type A manual call points shall be marked with the symbol in accordance with Figures 3 c). The operating face of type B manual call points shall be marked with the symbols in accordance with Figures 3 b) and 3 d). The symbol in accordance with Figure 3 b) shall point to the operating element and shall remain clearly visible when the frangible element is broken or displaced. These symbols may be supplemented by appropriate words for instruction. Where supplementary wording is used, this shall indicate position and/or operating action (e.g. "PRESS HERE").

These symbols and lettering for any supplementary instructions shall be black with the black area not exceeding 10 % of the area of the operating face.

NOTE A suitable black colour is specified in ISO 3864:1984.

**4.7.3.3.2** Markings other than specified in 4.7.3.3.1 (such as company logo or contact address) shall be restricted to the upper and/or the lower 25 % of the area of the operating face and shall not interfere with the symbols. The total area for this marking other than white shall not be greater than 5 % of the area of the operating face.



a) Symbol on the front face

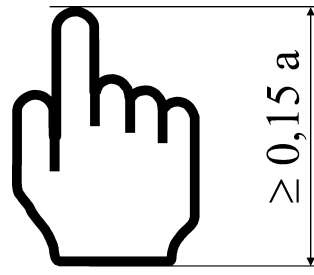

b) Symbol on the operating face for activating the operating element for type B manual call point

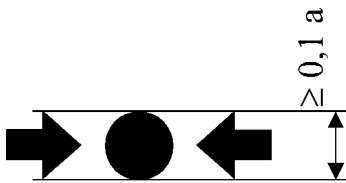

or

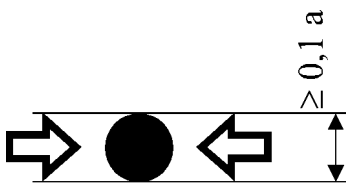

c) Symbol on the operating face for the arrows including the virtual button for type A manual call point

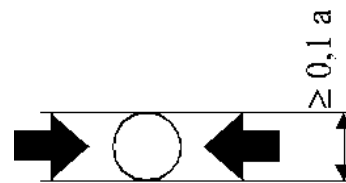

or

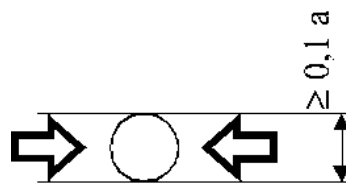

d) Symbol on the operating face for the arrows for type B manual call point (The virtual button may also be shown)

NOTE The dimensions and spacing of the symbols shall be in proportion to the height shown.

**Key**

*a* Height of the front face, see Table 1

**Figure 3 — Symbols used for manual call points**

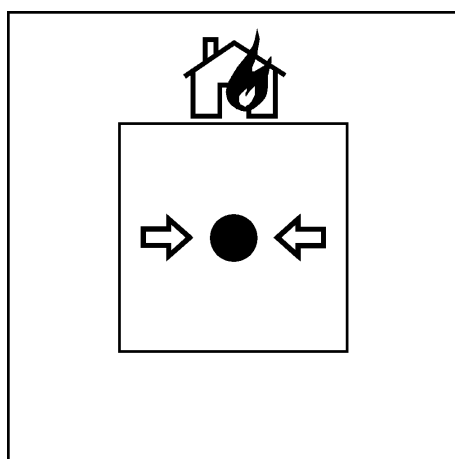

a) Example for using a square operating face

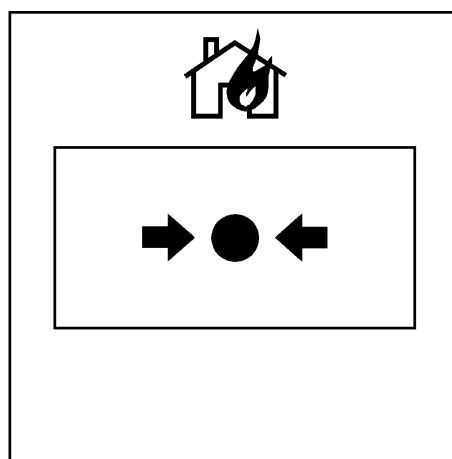

b) Example for using a rectangular operating face

Figure 4 — Example for the front and operating face symbol positions for type A manual call point

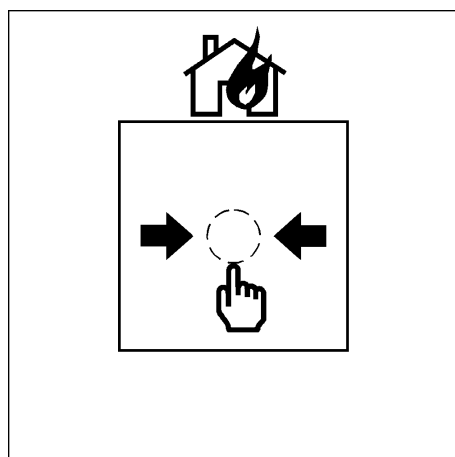

a) Example for using a square operating face

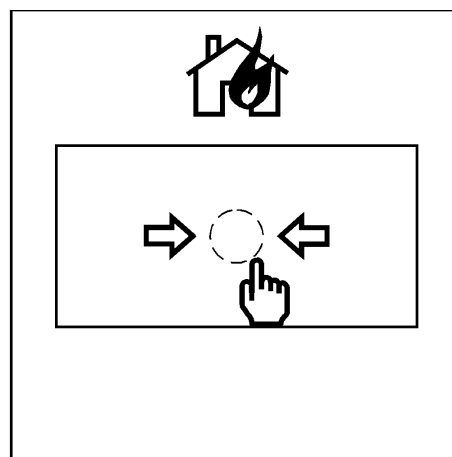

b) Example for using a rectangular operating face

NOTE The dotted outline represents the visible part of the operating element.

Figure 5 — Example for the front and operating face symbol positions for type B manual call point

#### 4.7.4 Protection against accidental operation

In addition to the use of the frangible element other means of protection may be used, e.g. a transparent flap.

Where used, the protection shall be easily and immediately removable and shall have clear instructions for its removal in order to operate the manual call point.

With the protection in place, the appearance of the manual call point, the instructions for its operation and the state of the manual call point in the normal and alarm condition shall be clearly visible.

#### 4.7.5 Environment category

The environment category (i.e. indoor or outdoor use, special environmental conditions) of the manual call point shall be specified by the manufacturer.

The manual call point shall be tested in accordance with the specified environmental category as given in the test schedule in Table 2.

### 4.8 Additional requirements for software controlled manual call points

#### 4.8.1 General

For manual call points which rely on software control in order to fulfil the requirements of this standard, the requirements of 4.8.2, 4.8.3 and 4.8.4 shall be met.

#### 4.8.2 Software documentation

**4.8.2.1** The manufacturer shall submit documentation which gives an overview of the software design. This documentation shall be in sufficient detail for the design to be inspected for compliance with this standard and shall include at least the following:

- a) A functional description of the main program flow (e.g. as a flow diagram or structogram) including:
  - 1) a brief description of the modules and the functions that they perform;
  - 2) the way in which the modules interact;
  - 3) the overall hierarchy of the program;
  - 4) the way in which the software interacts with the hardware of the manual call point;
  - 5) the way in which the modules are called, including any interrupt processing.
- b) A description of which areas of memory are used for the various purposes (e.g. the program, site specific data and running data).
- c) A designation, by which the software and its version can be uniquely identified.

**4.8.2.2** The manufacturer shall have available detailed design documentation, which only needs to be provided if required by the testing authority. It shall comprise at least the following:

- a) An overview of the whole system configuration, including all software and hardware components.
- b) A description of each module of the program, containing at least:
  - 1) the name of the module;
  - 2) description of the tasks performed;
  - 3) description of the interfaces, including the type of data transfer, the valid data range and the checking for valid data.
- c) Full source code listings, as hard copy or in machine-readable form (e.g. ASCII-code), including all global and local variables, constants and labels used, and sufficient comment for the program flow to be recognized.
- d) Details of any software tools used in the design and implementation phase (e.g. CASE-tools, compilers).



### 4.8.3 Software design

In order to ensure the reliability of the manual call point, the following requirements for software design shall apply:

- a) the software shall have a modular structure;
- b) the design of the interfaces for manually and automatically generated data shall not permit invalid data to cause error in the program operation;
- c) the software shall be designed to avoid the occurrence of deadlock of the programme flow.

### 4.8.4 The storage of programs and data

The program necessary to comply with this standard and any preset data, such as manufacturer's settings, shall be held in non-volatile memory. Writing to areas of memory containing this program and data shall only be possible by the use of some special tool or code and shall not be possible during normal operation of the manual call point.

Site-specific data shall be held in memory which will retain data for at least two weeks without external power to the manual call point, unless provision is made for the automatic renewal of such data, following loss of power, within 1 h of power being restored.

## 5 Tests

### 5.1 General

#### 5.1.1 Atmospheric conditions for tests

Unless otherwise stated in a test procedure, the testing shall be carried out after the test specimen has been allowed to stabilize in the standard atmospheric conditions for testing, as described in IEC 60068-1:1988, as follows:

- a) temperature: (15 to 35) °C;
- b) relative humidity: (25 to 75) %;
- c) air pressure: (86 to 106) kPa.

NOTE If variations in these parameters have a significant effect on a measurement, then such variations should be kept to a minimum during a series of measurements carried out as part of one test on one specimen.

#### 5.1.2 Operating conditions for tests

If a test method requires a specimen to be operational, then the specimen shall be connected to a suitable supply and monitoring equipment with characteristics as required by the manufacturer's data. Unless otherwise specified in the test method, the supply parameters applied to the specimen shall be set within the manufacturer's specified range(s) and shall remain substantially constant throughout the tests. The value chosen for each parameter shall normally be the nominal value, or the mean of the specified range. If a test procedure requires a specimen to be monitored to detect any alarm or fault signals, then connections shall be made to any necessary ancillary devices (e.g. through wiring to an end-of-line device for conventional manual call points) to allow a fault signal to be recognized.

NOTE The details of the supply and monitoring equipment and the alarm criteria used should be given in the test report.

#### 5.1.3 Mounting arrangements

The specimen shall be mounted by its normal means of attachment in accordance with the manufacturer's instructions. If these instructions describe more than one method of mounting, then the method considered to be most unfavourable shall be chosen for each test.

#### 5.1.4 Tolerances

Unless otherwise stated, the tolerances for the environmental test parameters shall be as given in the basic reference standards for the test (e.g. the relevant part of IEC 60068).

If a specific tolerance or deviation limit is not specified in a requirement or test procedure, then a deviation limit of  $\pm 5\%$  shall be applied.

#### 5.1.5 Measurement of response time

Where the release of an alarm signal in the following tests is required, the alarm signal shall be indicated at the supply and monitoring equipment (see 5.1.2) within a response time of 10 s after the operating element has been activated.

This response time shall be measured and reported.

#### 5.1.6 Provisions for tests

The following shall be provided for testing compliance with this European Standard:

- a) for manual call points that are simple switches or contain simple electronic components:
  - 8 specimens for indoor use; or
  - 9 specimens for outdoor use;
- b) for manual call points with active electronic components:
  - 13 specimens for indoor use; or
  - 14 specimens for outdoor use;
- c) 30 additional frangible elements if replacement of the element to reset the manual call point is necessary;
- d) the technical data sheets or specifications according to 4.2.2;
- e) additional technical information, if required, e.g. diagrams, design drawings with dimensions, parts lists and material data.

The specimens submitted shall be representative of the manufacturer's normal production with regard to their construction and settings.

#### 5.1.7 Test schedule

The specimens shall be randomly numbered:

- a) 1 to 8, if they are for indoor use and are simple switches or contain simple electronic components;
- b) 1 to 13, if they are for indoor use and contain active electronic components;
- c) 1 to 8 and 14, if they are for outdoor use and are simple switches or contain simple electronic components;
- d) 1 to 14, if they are for outdoor use and contain active electronic components.

Any change in the number and numbering of specimens, e.g. in line with Table 2, shall be recorded in the test report accordingly.

All specimens shall be initially tested in accordance with the test facility test of 5.4 and then be tested in accordance with Table 2.

**Table 2 — Test Schedule**

Test	Number of specimen	Clause number	Indoor use	Outdoor use
Variation of supply parameters	2	5.6	×	×
Dry heat (operational)	1	5.7	×	×
Dry heat (endurance)	1	5.8	—	×
Cold (operational)	2	5.9	×	×
Damp heat, cyclic (operational)	3	5.10	×	×
Damp heat, cyclic (endurance)	3	5.11	—	×
Damp heat, steady state (endurance)	4	5.12	×	×
SO <sub>2</sub> corrosion (endurance)	5	5.13	×	×
Shock (operational)	6	5.14	×	×
Impact (operational)	7	5.15	×	×
Vibration (operational)	8	5.16	×	×
Vibration (endurance)	8	5.17	×	×
Electromagnetic compatibility (operational) <sup>a</sup> ; i.e.		5.18	×	×
a) electrostatic discharge	9 <sup>b</sup>			
b) radiated electromagnetic fields	10 <sup>b</sup>			
c) conducted disturbances induced by electromagnetic fields	1 <sup>b</sup>			
d) voltage transient, fast transient bursts	12 <sup>b</sup>			
e) voltage transient, slow high-energy voltage surge	13 <sup>b</sup>			
Enclosure protection	14	5.19	—	×
<p><sup>a</sup> Test only for manual call points with active electronic components.</p> <p><sup>b</sup> In the interests of test economy, it is permitted to use the same specimen for more than one EMC test. In that case, intermediate functional test(s) on the specimen(s) used for more than one test may be deleted, and the full functional test conducted at the end of the sequence of tests. However, it should be noted that in the event of a failure, it shall not be possible to identify which test exposure caused the failure (see EN 50130-4:1995, clause 4).</p>				

## 5.2 Operational performance test

### 5.2.1 Object

To demonstrate that the manual call point is able to withstand small forces to the frangible element without operation, is able to operate when an appropriate force is applied to the frangible element by the user and that its reset and test facilities are not impaired.

### 5.2.2 Test procedure

#### 5.2.2.1 Test for non-operation

##### 5.2.2.1.1 State of the specimen during test

The specimen shall be mounted in accordance with 5.1.3 and connected to a suitable supply and monitoring equipment as described in 5.1.2.

#### **5.2.2.1.2 Initial state**

At the start of the test the specimen shall be in its normal condition.

#### **5.2.2.1.3 Conditioning**

The frangible element shall be subjected to a horizontal force increasing at a rate not exceeding  $5 \text{ N s}^{-1}$  until it reaches  $(22,5 \pm 2,5) \text{ N}$ . This force is maintained for 5 s then released at a rate not exceeding  $5 \text{ N s}^{-1}$ . The position where this force shall be subjected is the centre point between the arrows, see Figures 3 c) and 3 d).

An example of a suitable test apparatus is shown in annex B.

#### **5.2.2.1.4 Measurements during testing**

The specimen shall be monitored during the test period to detect any alarm or fault signals.

#### **5.2.2.1.5 Final measurements**

- a) After the force has been released, the frangible element shall be examined.
- b) The specimen shall then be tested as described in the test facility test of 5.4.

#### **5.2.2.2 Test for operation**

##### **5.2.2.2.1 Conditioning**

The frangible element shall be subjected to a horizontal impact within 5 mm of the centre point between the arrows, see Figures 3 c) and 3 d).

The impact shall be produced by using the test apparatus in accordance with annex A.

The ball shall strike the specimen once only.

For type B manual call points, the operating element shall then be manually operated.

##### **5.2.2.2.2 State of the specimen during test**

The specimen shall be mounted on the test apparatus (see annex A) in its normal operating position in accordance with 5.1.3 and connected to a suitable supply and monitoring equipment as described in 5.1.2.

##### **5.2.2.2.3 Initial state**

At the start of the test the specimen shall be in its normal condition.

##### **5.2.2.2.4 Resetting**

After operation, the specimen shall be reset to its normal condition by using the reset facility of 4.5.

##### **5.2.2.2.5 Measurements during testing**

The specimen shall be monitored during the test and resetting period to detect any alarm or fault signals.

#### **5.2.3 Test requirements**

The specimen shall satisfy the following requirements:

- a) in the test of 5.2.2.1 the frangible element shall not transfer into the alarm condition and no alarm or fault signal shall be given, except as required in the test of 5.2.2.1.5 b). In the test of 5.2.2.1.5 b) the specimen shall comply with the requirements of 5.4.3;

- b) for type A - in the test of 5.2.2.2 the frangible element shall transfer into the alarm condition and an alarm signal shall be given in accordance with 5.1.5. After the specimen has been reset by use of the reset facility of 4.5 there shall be no alarm or fault signal;
- c) for type B - in the test of 5.2.2.2 the frangible element shall transfer into the alarm condition and an alarm signal shall be given in accordance with 5.1.5 after activation of the operating element. After the specimen has been reset by use of the reset facility of 4.5 there shall be no alarm or fault signal.

### **5.3 Function test**

#### **5.3.1 Object**

To demonstrate the ability of the electrical parts of the manual call point to function correctly.

#### **5.3.2 Test procedure**

The test may be performed as described in 5.2.2.2 (test for operation) or using the test facility according to 4.6 or some other means which activate the operating element.

NOTE This can be parts or combinations of the operational performance test and the test facility test with suitable modifications to help the test laboratories to carry out the environmental tests.

For the dry heat (operational) test according to 5.7 and cold (operational) test according to 5.9, the function tests during conditioning [see 5.7.2.4 b) and 5.9.2.4 b) respectively] shall use a procedure which does not result in breakage of the frangible element.

#### **5.3.3 Test requirements**

An alarm signal shall be given in accordance with 5.1.5 when the operating element has been activated.

### **5.4 Test facility test (operational)**

#### **5.4.1 Object**

To demonstrate the ability of the test facility (see 4.6) of the manual call point to function correctly.

#### **5.4.2 Test procedure**

##### **5.4.2.1 General**

The test shall be carried out in accordance with the manufacturer's instructions for routine testing by using the test facility of 4.6.

##### **5.4.2.2 State of the specimen during test**

The specimen shall be mounted in accordance with 5.1.3 and connected to a suitable supply and monitoring equipment as described in 5.1.2.

##### **5.4.2.3 Measurements during testing**

The specimen shall be monitored during the test period to detect any alarm or fault signals.

#### **5.4.3 Test requirements**

The following requirements shall be satisfied:

- a) an alarm signal shall be given in accordance with 5.1.5 when the test facility has been operated;
- b) no fault signal shall be given during the test;
- c) when reset in accordance with the manufacturer's instructions, the specimen shall return to its normal condition.

## **5.5 Reliability test (endurance)**

### **5.5.1 Object**

To demonstrate the reliability of the operating element.

### **5.5.2 Test procedure**

#### **5.5.2.1 Test apparatus**

A suitable method of activating and resetting the operating element shall be used, which for type A simulates the frangible element's alarm condition followed by the resetting to its normal condition and for type B activates and resets the operating element with the frangible element removed.

NOTE If suitable, the test facility of 4.6 can be used for this test.

#### **5.5.2.2 State of the specimen during conditioning**

The specimen shall be mounted in accordance with 5.1.3 and connected to a suitable supply and monitoring equipment as described in 5.1.2. The supply parameters shall be adjusted within the manufacturer's specifications for conditions most likely to cause failure.

#### **5.5.2.3 Conditioning**

The following severity shall be applied:

The operating element shall be activated and reset 250 times.

#### **5.5.2.4 Final measurements**

- a) The specimen shall be checked visually for any damage.
- b) The specimen shall be tested as described in the operational performance test of 5.2.

### **5.5.3 Test requirements**

The following requirements shall be satisfied:

- a) There shall be no visible damage to the specimen likely to impair its operation.
- b) In the test of 5.5.2.4 b) the specimen shall comply with the requirements of 5.2.3.

## **5.6 Variation of supply parameters**

### **5.6.1 Objects**

To demonstrate that within the manufacturer's specified upper and lower limits of the supply parameters, the ability of the manual call point to signal an alarm is not unduly dependent on these parameters for correct operation.

### **5.6.2 Test procedure**

#### **5.6.2.1 State of the specimen during conditioning**

The specimen shall be connected to a suitable supply and monitoring equipment as described in 5.1.2.

#### **5.6.2.2 Conditioning**

The supply parameters shall be set within the manufacturer's specifications to the upper limit for a period of 5 min and then to the lower limit for a period of 5 min. The values of the parameters shall be reported.

### 5.6.2.3 Measurements during conditioning

- a) The specimen shall be monitored during the conditioning period to detect any alarm or fault signals.
- b) At the end of each conditioning period the function test of 5.3 shall be carried out at the upper and lower limits respectively.
- c) The specimen shall be reset after each function test.

### 5.6.3 Test requirements

The following requirements shall be satisfied:

- a) No alarm or fault signals shall be given during the conditioning period, except as required in the tests of 5.6.2.3 b).
- b) In the test of 5.6.2.3 b) the specimen shall comply with the requirements of 5.3.3.
- c) After the specimen has been reset there shall be no alarm or fault signal.

## 5.7 Dry heat (operational)

### 5.7.1 Object

To demonstrate the ability of the manual call point to function correctly at high ambient temperatures, which may occur for short periods in the anticipated service environment.

### 5.7.2 Test procedure

#### 5.7.2.1 Reference

The test apparatus and the test procedure shall be as described in IEC 60068-2-2:1974, IEC 60068-2-2/A1:1993 and IEC 60068-2-2/A2:1994, test Bb.

#### 5.7.2.2 State of the specimen during conditioning

The specimen shall be mounted in accordance with 5.1.3 and connected to a suitable supply and monitoring equipment as described in 5.1.2. The supply parameters shall be adjusted within the manufacturer's specifications for conditions most likely to cause failure.

#### 5.7.2.3 Conditioning

The appropriate test conditions in Table 3 shall be applied.

**Table 3 — Conditions for dry heat (operational) test**

Parameters	Indoor use	Outdoor use
Temperature, °C	55 ± 2	70 ± 2
Duration, h	16	

#### 5.7.2.4 Measurements during conditioning

- a) The specimen shall be monitored during the conditioning period to detect any alarm or fault signals.
- b) During the last half hour of the conditioning period, the function test of 5.3 shall be carried out.

### 5.7.2.5 Final measurements

After a recovery period of at least 1 h at standard atmospheric conditions in accordance with 5.1.1, the specimen shall be reset and then be tested as described in the operational performance test of 5.2.

The dry heat operational and endurance tests may be combined such that the specimen for outdoor use is subjected to the operational test conditioning followed (after resetting) by the endurance test conditioning. Only one final measurement shall be made.

### 5.7.3 Test requirements

The following requirements shall be satisfied:

- a) No alarm or fault signal shall be given during the conditioning period, except as required in the test of 5.7.2.4.
- b) In the test of 5.7.2.4 b) the specimen shall comply with the requirements of 5.3.3.
- c) In the test of 5.7.2.5 the specimen shall comply with the requirements of 5.2.3.

## 5.8 Dry heat (endurance)

### 5.8.1 Object

To demonstrate the ability of the manual call point to withstand long term ageing effects.

### 5.8.2 Test procedure

#### 5.8.2.1 Reference

The test apparatus and the test procedure shall be as described in IEC 60068-2-2:1974, IEC 60068-2-2/A1:1993 and IEC 60068-2-2/A2:1994, test Bb.

#### 5.8.2.2 State of the specimen during conditioning

The specimen shall be mounted in accordance with 5.1.3 and not supplied with power during the conditioning.

#### 5.8.2.3 Conditioning

The appropriate test conditions in Table 4 shall be applied.

**Table 4 — Conditions for dry heat (endurance) test**

Parameters	Indoor use	Outdoor use
Temperature, °C	No test	70 ± 2
Duration, d		21

#### 5.8.2.4 Final measurements

After a recovery period of at least 1 h at standard atmospheric conditions in accordance with 5.1.1, the specimen shall be tested as described in the reliability test of 5.5.

### 5.8.3 Test requirements

The following requirements shall be satisfied:

- a) No fault signal attributable to the endurance conditioning shall be given on connection of the specimen.
- b) In the test of 5.8.2.4 the specimen shall comply with the requirements of 5.5.3.



## 5.9 Cold (operational)

### 5.9.1 Object

To demonstrate the ability of the manual call point to function correctly at low ambient temperatures appropriate to the anticipated service environment.

### 5.9.2 Test procedure

#### 5.9.2.1 Reference

The test apparatus and the test procedure shall be as described in IEC 60068-2-1:1990, IEC 60068-2-1/A1:1993 and IEC 60068-2-1/A2:1994 , test Ab.

#### 5.9.2.2 State of the specimen during conditioning

The specimen shall be mounted in accordance with 5.1.3 and connected to a suitable supply and monitoring equipment as described in 5.1.2. The supply parameters shall be adjusted within the manufacturer's specifications for conditions most likely to cause failure.

#### 5.9.2.3 Conditioning

The appropriate test conditions in Table 5 shall be applied.

**Table 5 — Conditions for cold (operational) test**

Parameters	Indoor use	Outdoor use
Temperature, °C	-10 ± 3	-25 ± 3 <sup>a</sup>
Duration, h	16	
<sup>a</sup> For countries with special cold conditions: (-40 ± 3) °C		

#### 5.9.2.4 Measurements during conditioning

- a) The specimen shall be monitored during the conditioning period to detect any alarm or fault signals.
- b) During the last half hour of the conditioning period, the function test of 5.3 shall be carried out.

#### 5.9.2.5 Final measurements

After a recovery period of at least 1 h at standard atmospheric conditions in accordance with 5.1.1, the specimen shall be reset and then be tested as described in the operational performance test of 5.2.

### 5.9.3 Test requirements

The following requirements shall be satisfied:

- a) No alarm or fault signal shall be given during the conditioning period, except as required in the test of 5.9.2.4.
- b) In the test of 5.9.2.4 b) the specimen shall comply with the requirements of 5.3.3.
- c) In the test of 5.9.2.5 the specimen shall comply with the requirements of 5.2.3.

## 5.10 Damp heat, cyclic (operational)

### 5.10.1 Object

To demonstrate the ability of the manual call point to function correctly at high relative humidity, where condensation occurs on the manual call point.

### 5.10.2 Test procedure

#### 5.10.2.1 Reference

The test apparatus and the test procedure shall be as described in IEC 60068-2-30:1980 and IEC 60068-2-30/A1:1985, test Db, using the Variant 1 test cycle and controlled recovery conditions.

#### 5.10.2.2 State of the specimen during conditioning

The specimen shall be mounted in accordance with 5.1.3 and connected to a suitable supply and monitoring equipment as described in 5.1.2. The supply parameters shall be adjusted within the manufacturer's specifications for conditions most likely to cause failure.

#### 5.10.2.3 Conditioning

The appropriate test conditions in Table 6 shall be applied.

**Table 6 — Conditions for damp heat, cyclic (operational) test**

Parameters	Indoor use	Outdoor use
Lower temperature, °C	25 ± 3	
Relative humidity (lower temperature), %	> 95	
Upper temperature, °C	40 ± 2	55 ± 2
Relative humidity (upper temperature), %	93 ± 3	
Number of cycles	2	

#### 5.10.2.4 Measurements during conditioning

The specimen shall be monitored during the conditioning period to detect any alarm or fault signals.

#### 5.10.2.5 Final measurements

After the recovery period specified in IEC 60068-2-30:1980 and IEC 60068-2-30/A1:1985, the specimen shall be tested as described in the operational performance test of 5.2.

The damp heat, cyclic operational and endurance tests may be combined such that the specimen for outdoor use is subjected to the operational test conditioning followed by the endurance test conditioning. Only one final measurement shall be made.

### 5.10.3 Test requirements

The following requirements shall be satisfied:

- a) No alarm or fault signals shall be given during the conditioning period.
- b) In the test of 5.10.2.5 the specimen shall comply with the requirements of 5.2.3.

## 5.11 Damp heat, cyclic (endurance)

### 5.11.1 Object

To demonstrate the ability of the manual call point to withstand the longer term effects of high humidity and condensation.

### 5.11.2 Test procedure

#### 5.11.2.1 Reference

The test apparatus and the test procedure shall be as described in IEC 60068-2-30:1980 and IEC 60068-2-30/ A1:1985, test Db, using the Variant 1 test cycle and controlled recovery conditions.

#### 5.11.2.2 State of the specimen during conditioning

The specimen shall be mounted in accordance with 5.1.3 and not supplied with power during the conditioning.

#### 5.11.2.3 Conditioning

The appropriate test conditions in Table 7 shall be applied.

**Table 7 — Conditions for damp heat, cyclic (endurance) test**

Parameters	Indoor use	Outdoor use
Lower temperature, °C	No test	25 ± 3
Relative humidity (lower temperature), %		> 95
Upper temperature, °C		55 ± 2
Relative humidity (upper temperature), %		93 ± 3
Number of cycles		6

#### 5.11.2.4 Final measurements

After the recovery period specified in IEC 60068-2-30:1980 and IEC 60068-2-30/A1:1985, the specimen shall be tested as described in the operational performance test of 5.2.

### 5.11.3 Test requirements

The following requirements shall be satisfied:

- a) No fault signal attributable to the endurance conditioning shall be given on connection of the specimen.
- b) In the test of 5.11.2.4 the specimen shall comply with the requirements of 5.2.3.

## 5.12 Damp heat, steady state (endurance)

### 5.12.1 Object

To demonstrate the ability of the manual call point to withstand the long term effects of humidity in the service environment (e.g. changes in electrical properties due to absorption, chemical reactions involving moisture, galvanic corrosion).

## 5.12.2 Test procedure

### 5.12.2.1 Reference

The test apparatus and the test procedure shall be as described in IEC 60068-2-56:1988, test Cb. If this is impracticable, the test apparatus and the test procedure may be used as described in IEC 60068-2-3:1969, test Ca.

### 5.12.2.2 State of the specimen during conditioning

The specimen shall be mounted in accordance with 5.1.3 and not supplied with power during the conditioning.

### 5.12.2.3 Conditioning

The test conditions in Table 8 shall be applied.

**Table 8 — Conditions for damp heat, steady state (endurance) test**

Parameters	Indoor use	Outdoor use
Temperature, °C	40 ± 2	
Relative humidity, %	93 ± 3	
Duration, d	21	

### 5.12.2.4 Final measurements

After a recovery period of at least 1 h at standard atmospheric conditions in accordance with 5.1.1, the specimen shall be tested as described in the reliability test of 5.5.

## 5.12.3 Test requirements

The following requirements shall be satisfied:

- a) No fault signal attributable to the endurance conditioning shall be given on connection of the specimen.
- b) In the test of 5.12.2.4 the specimen shall comply with the requirements of 5.5.3.

## 5.13 SO<sub>2</sub> corrosion (endurance)

### 5.13.1 Object

To demonstrate the ability of the manual call point to withstand the corrosive effects of sulfur dioxide as an atmospheric pollutant.

### 5.13.2 Test procedure

#### 5.13.2.1 Reference

The test apparatus and the test procedure shall be as described in IEC 60068-2-42:1982, test Kc, except for the relative humidity of the test atmosphere, which shall be (93 ± 3) % instead of (75 ± 5) %.

#### 5.13.2.2 State of the specimen during conditioning

The specimen shall be mounted in accordance with 5.1.3. It shall not be supplied with power, but shall have untinned copper wires of the appropriate diameter connected to sufficient terminals, to allow the final measurements to be made, without making further connections to the specimen.

### 5.13.2.3 Conditioning

The test conditions in Table 9 shall be applied.

**Table 9 — Conditions for SO<sub>2</sub> corrosion (endurance) test**

Parameters	Indoor use	Outdoor use
Sulfur dioxide content, cm <sup>3</sup> m <sup>-3</sup> <sup>a</sup>	25 ± 5	
Temperature, °C	25 ± 2	
Relative humidity, %	93 ± 3	
Duration, d	21	
<sup>a</sup> Corresponding to ppm per volume in IEC 60068-2-42:1982.		

### 5.13.2.4 Final measurements

Immediately after the conditioning the specimen shall be subjected to a drying period of 16 h at (40 ± 2) °C, and relative humidity of ≤ 50 %, followed by a recovery period of 1 h to 2 h at standard atmospheric conditions in accordance with 5.1.1.

After the recovery period the specimen shall be tested as described in the operational performance test of 5.2.

### 5.13.3 Test requirements

The following requirements shall be satisfied:

- a) No fault signal attributable to the endurance conditioning shall be given on connection of the specimen.
- b) In the test of 5.13.2.4 the specimen shall comply with the requirements of 5.2.3.

## 5.14 Shock (operational)

### 5.14.1 Object

To demonstrate the immunity of the manual call point to mechanical shocks, which are likely to occur, albeit infrequently, in the anticipated service environment.

### 5.14.2 Test procedure

#### 5.14.2.1 Reference

The test apparatus and the test procedure shall be as described in IEC 60068-2-27:1987, test Ea, for a half sine wave pulse but with the peak acceleration related to the specimen mass as indicated in Table 10.

#### 5.14.2.2 State of the specimen during conditioning

The specimen shall be mounted in accordance with 5.1.3 to a rigid fixture and connected to a suitable supply and monitoring equipment as described in 5.1.2.

#### 5.14.2.3 Conditioning

For specimens with a mass  $M \leq 4,75$  kg the test conditions in Table 10 shall be applied. No test is applied to specimens with a mass  $M > 4,75$  kg.

**Table 10 — Conditions for shock (operational) test**

Parameters	Indoor use	Outdoor use
Shock pulse type	Half sine	
Pulse duration, ms	6	
Peak acceleration, $m\ s^{-2}$	10 (100 - 20 <i>M</i> )	
Number of directions	6	
Pulses per direction	3	

#### 5.14.2.4 Measurements during conditioning

The specimen shall be monitored during the conditioning period and for a further 2 min to detect any alarm or fault signals.

#### 5.14.2.5 Final measurements

After the conditioning, the specimen shall be tested as described in the operational performance test of 5.2.

#### 5.14.3 Test requirements

The following requirements shall be satisfied:

- a) No alarm or fault signals shall be given during the conditioning period or the additional 2 min.
- b) In the test of 5.14.2.5 the specimen shall comply with the requirements of 5.2.3.

### 5.15 Impact (operational)

#### 5.15.1 Object

To demonstrate the immunity of the manual call point to mechanical impacts upon its surface, which it may sustain in the normal service environment, and which it can reasonably be expected to withstand.

#### 5.15.2 Test procedure

##### 5.15.2.1 Apparatus

The test apparatus shall consist of a swinging hammer incorporating a rectangular-section aluminium alloy head (aluminium alloy AlCu<sub>4</sub>SiMg complying with ISO 209-1:1989, solution treated and precipitation treated condition) with the plane impact face chamfered to an angle of 60° to the horizontal, when in the striking position (i.e. when the hammer shaft is vertical). The hammerhead shall be (50 ± 2,5) mm high, (76 ± 3,8) mm wide and (80 ± 4) mm long at mid height as shown in Figure C.1. A suitable apparatus is described in annex C.

The hard wood mounting board shall have width and height dimensions of not less than 20 mm greater than the dimensions *a* and *b* in Figures 1 and 2 and a minimum thickness of 40 mm and a minimum mass of not less than 5 times that of the manual call point. It shall be fixed to the rigid frame to allow the manual call point to be located in the positions shown in Figure C.2 and Figure C.3.

##### 5.15.2.2 State of the specimen during conditioning

The specimen shall be mounted to the test apparatus in accordance with 5.1.3 and connected to a suitable supply and monitoring equipment as described in 5.1.2. It shall be positioned so that it is struck by the middle of the lower half of the impact face when the hammer is in the vertical position (i.e. when the hammerhead is moving horizontally). A first impact shall be applied to the specimen from the side to the left or right lower side edge where the hammerhead is moving (in parallel) not more than 5 mm apart from the specimen's mounting board (see Figure C.2). A second impact shall be applied from the front to the central part of the lower edge of the front face (see Figure C.3).

### 5.15.2.3 Conditioning

The test conditions in Table 11 shall be applied.

**Table 11 — Conditions for impact (operational) test**

Parameters	Indoor use	Outdoor use
Impact energy, J	1,9 ± 0,1	
Hammer velocity, m s <sup>-1</sup>	1,5 ± 0,13	
Number of impact positions	2	
Number of impacts per position	1	

### 5.15.2.4 Measurements during conditioning

The specimen shall be monitored during the conditioning period and for a further 2 min to detect any alarm or fault signals.

### 5.15.2.5 Final measurements

After the conditioning, the specimen shall be tested as described in the operational performance test of 5.2.

### 5.15.3 Test requirements

The following requirements shall be satisfied:

- a) No alarm or fault signals shall be given during the conditioning period or the additional 2 min.
- b) In the test of 5.15.2.5 the specimen shall comply with the requirements of 5.2.3.

## 5.16 Vibration, sinusoidal (operational)

### 5.16.1 Object

To demonstrate the immunity of the manual call point to vibration at levels considered appropriate to the normal service environment.

### 5.16.2 Test procedure

#### 5.16.2.1 Reference

The test apparatus and the test procedure shall be as described in IEC 60068-2-6:1995, test Fc.

#### 5.16.2.2 State of the specimen during conditioning

The specimen shall be mounted to the test apparatus in accordance with 5.1.3 and connected to a suitable supply and monitoring equipment as described in 5.1.2

The vibration shall be applied in each of three mutually perpendicular axes, in turn. The specimen shall be mounted so that one of the three axes is perpendicular to its normal mounting plane.

### 5.16.2.3 Conditioning

The test conditions in Table 12 shall be applied.

**Table 12 — Conditions for vibration, sinusoidal (operational) test**

Parameters	Indoor use	Outdoor use
Frequency range, Hz	10 to 150	
Acceleration amplitude, $\text{m s}^{-2}$	5 ( $\approx 0,5 g_n$ )	
Number of axes	3	
Sweep rate, octave $\text{min}^{-1}$	1	
Number of sweep cycles per axis	1	

### 5.16.2.4 Measurements during conditioning

The specimen shall be monitored during the conditioning period to detect any alarm or fault signals.

### 5.16.2.5 Final measurements

After the conditioning, the specimen shall be tested as described in the operational performance test of 5.2.

The vibration operational and endurance tests may be combined such that the specimen is subjected to the operational test conditioning followed by the endurance test conditioning in one axis before changing to the next axis. Only one final measurement shall be made.

### 5.16.3 Test requirements

The following requirements shall be satisfied:

- a) No alarm or fault signals shall be given during the conditioning period.
- b) In the test of 5.16.2.5 the specimen shall comply with the requirements of 5.2.3.

## 5.17 Vibration, sinusoidal (endurance)

### 5.17.1 Object

To demonstrate the ability of the manual call point to withstand the long term effects of vibration at levels appropriate to the normal service environment.

### 5.17.2 Test Procedure

#### 5.17.2.1 Reference

The test apparatus and the test procedure shall be as described in IEC 60068-2-6:1995, test Fc.

#### 5.17.2.2 State of the specimen during conditioning

The specimen shall be mounted to the test apparatus in accordance with 5.1.3 and not supplied with power during the conditioning.

The vibration shall be applied in each of three mutually perpendicular axes, in turn. The specimen shall be mounted so that one of the three axes is perpendicular to its normal mounting plane.

#### 5.17.2.3 Conditioning

The test conditions in Table 13 shall be applied.



**Table 13 — Conditions for vibration, sinusoidal (endurance) test**

Parameters	Indoor use	Outdoor use
Frequency range, Hz	10 to 150	
Acceleration amplitude, $\text{m s}^{-2}$	10 ( $\approx 1 g_n$ )	
Number of axes	3	
Sweep rate, octave $\text{min}^{-1}$	1	
Number of sweep cycles per axis	20	

#### 5.17.2.4 Final measurements

After the conditioning, the specimen shall be tested as described in the operational performance test of 5.2.

#### 5.17.3 Test requirements

The following requirements shall be satisfied:

- a) No fault signal attributable to the endurance conditioning shall be given on connection of the specimen.
- b) In the test of 5.17.2.4 the specimen shall comply with the requirements of 5.2.3.

### 5.18 Electromagnetic compatibility (EMC) (operational)

#### 5.18.1 Object

To demonstrate the capability of the manual call point to comply with the EMC immunity requirements in its normal service environment.

#### 5.18.2 Test procedure

##### 5.18.2.1 Reference

The test apparatus and the test procedures shall be as described in EN 50130-4:1995. The following tests shall be applied:

- a) Electrostatic discharge.
- b) Radiated electromagnetic fields.
- c) Conducted disturbances induced by electromagnetic fields.
- d) Fast transient burst.
- e) Slow high energy voltage surges.

##### 5.18.2.2 State of the specimen during conditioning

The specimen shall be mounted in accordance with 5.1.3 and connected to a suitable supply and monitoring equipment as described in 5.1.2

##### 5.18.2.3 Conditioning

The test conditions specified in EN 50130-4:1995 for the tests listed in 5.18.2.1 shall be applied.

##### 5.18.2.4 Measurement during conditioning

The specimen shall be monitored during the conditioning period to detect any alarm or fault signals.

### 5.18.2.5 Final measurements

After the conditioning, period, the function test of 5.3 shall be carried out. The specimen shall be reset after the function test.

### 5.18.3 Test requirements

The following requirements shall be satisfied:

- a) No alarm or fault signals shall be given during the conditioning period.
- b) In the test of 5.18.2.5 the specimen shall comply with the requirements of 5.3.3.
- c) After the specimen has been reset there shall be no alarm or fault signal.

## 5.19 Enclosure protection

### 5.19.1 Object

To demonstrate that the manual call point is adequately protected against the ingress of water.

### 5.19.2 Test procedure

#### 5.19.2.1 Reference

The test apparatus and the test procedure shall be as described in IEC 60068-2-18:1989 and IEC 60068-2-18/A1:1993, test Rb2.1.

#### 5.19.2.2 State of the specimen during conditioning

The specimen shall be mounted to the apparatus in accordance with 5.1.3 and connected to a suitable supply and monitoring equipment as described in 5.1.2.

#### 5.19.2.3 Conditioning

The appropriate test conditions in Table 14 shall be applied.

**Table 14 — Conditions for enclosure protection test**

Parameters	Indoor use	Outdoor use
Spray nozzle angle $\alpha$ , °	No test	$\pm 90$
Tube oscillating angle $\beta$ , °		$\pm 180$
Water flow per nozzle, $\text{dm}^3 \text{min}^{-1}$		0,10
Nozzle orifice diameter, mm		0,40
Over pressure, kPa		80
Duration, min		10

#### 5.19.2.4 Measurement during conditioning

The specimen shall be monitored during the conditioning period to detect any alarm or fault signals.

#### 5.19.2.5 Final measurements

After the conditioning, the specimen shall be tested as described in the operational performance test of 5.2.

### **5.19.3 Test requirements**

The following requirements shall be satisfied:

- a) No alarm or fault signals shall be given during the conditioning period.
- b) In the test of 5.19.2.5 the specimen shall comply with the requirements of 5.2.3.

## Annex A (normative)

### Test apparatus for test for operation

The test apparatus for test for operation shall be as shown in Figure A.1. The apparatus consists of a brass spherical ball (1) suspended by a woven cord (1c) in front of the vertical face of the manual call point mounted on a suitable frame. The points of suspension (2) can be adjusted vertically and horizontally, so that the point (6) at which the brass ball strikes the defined area of operation on the frangible element indicated by the symbols within the operating face, is in the vertical plane. The suspension distance between (2) and (6) shall not be less than 420 mm.

To operate, the ball is swung back and located into a release mechanism, which holds the ball at the height defined by (3) in Figure A.1. The mechanism is then released allowing the ball to swing freely through an arc, defined by the suspension point, and strike the frangible element with a single blow.

The mounting board on which the manual call point is fixed, is part of the rigid frame to which the ball suspension and the release mechanism are a part.

Dimensions in millimetres

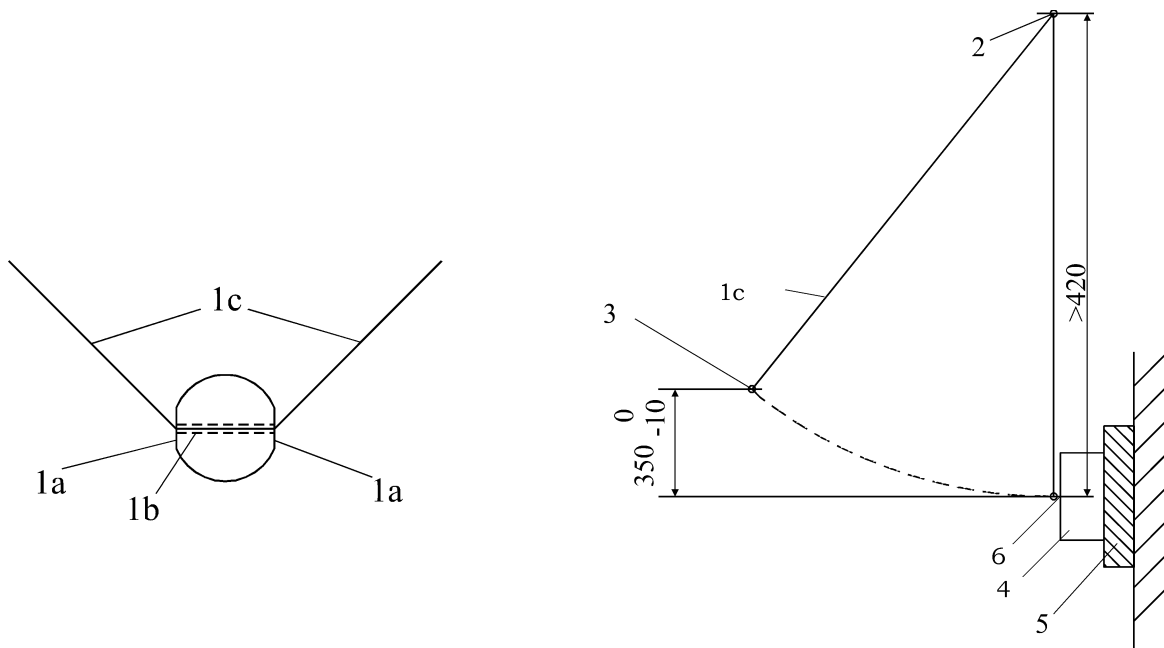

**a) Details of the brass ball with a total mass of  $85 \text{ g} \pm 1 \text{ g}$**

**b) Principle of the test apparatus**

**Key**

- 1a Flats to adjust the mass
- 1b Hole through the spherical brass ball with a diameter of  $(1,2^{+0,2}_0)$  mm
- 1c Woven cord with a diameter of 1,2 mm
- 2 Suspension points on the vertical frame
- 3 Centre of mass of the brass ball
- 4 Manual call point
- 5 Wooden mounting board as described in 5.15.2.1, clamped to the rigid frame
- 6 Centre of the strike point on the frangible element

**Figure A.1 — Test apparatus for test for operation**

**Annex B**  
(informative)

**Test apparatus for test for non-operation**

A suitable test apparatus for test for non-operation is shown in Figure B.1.

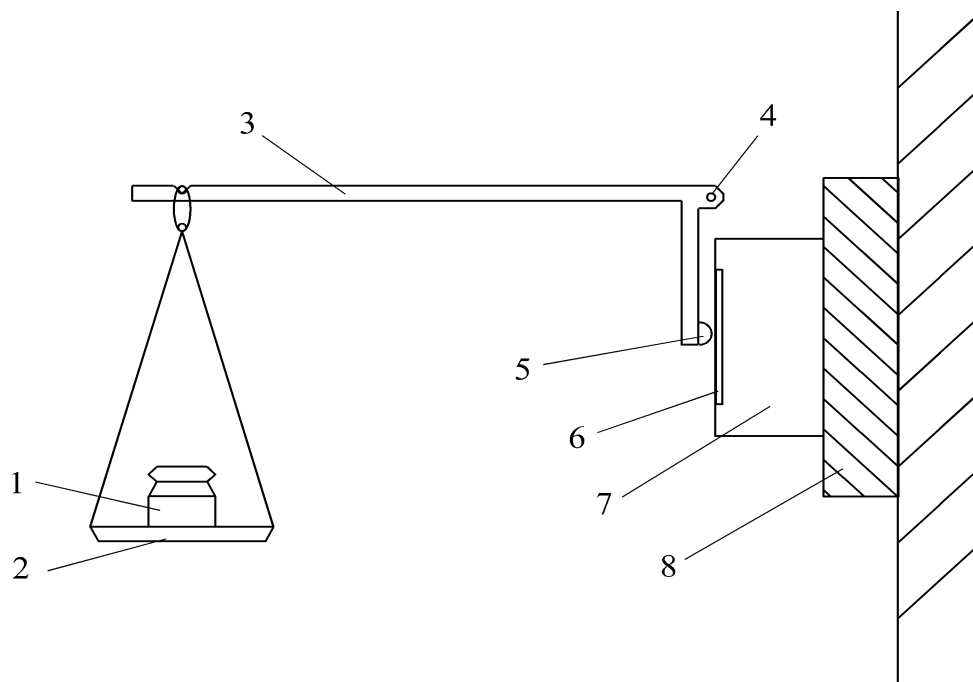

**Key**

- 1 Mass
- 2 Pan
- 3 Metal rod
- 4 Pivot
- 5 Rubber
- 6 Frangible element
- 7 Manual call point
- 8 Wooden block clamped to rigid surface shown (wooden mounting board as described in 5.15.2.1)

**Figure B.1 — Test apparatus for test for non-operation**

## Annex C (informative)

### Test apparatus for the impact test

The apparatus for the impact (see Figure C.1) consists essentially of a swinging hammer comprising a rectangular section head (striker), with a chamfered impact face, mounted on a tubular steel shaft. The hammer is fixed into a steel boss, which runs on ball bearings on a fixed steel shaft mounted in a rigid steel frame, so that the hammer can rotate freely about the axis of the fixed shaft. The design of the rigid frame is such as to allow complete rotation of the hammer assembly when the manual call point and its mounting board are not present.

The striker is of dimensions 76 mm wide, 50 mm high and 94 mm long (overall dimensions) and is manufactured from aluminium alloy (AlCu<sub>4</sub>SiMg according to ISO 209-1:1989), solution treated and precipitation treated condition. It has a plane impact face chamfered at  $(60 \pm 1)^\circ$  to the long axis of the head. The tubular steel shaft has an outside diameter of  $(25 \pm 0,1)$  mm with walls  $(1,6 \pm 0,1)$  mm thick.

The striker is mounted on the shaft so that its long axis is at a radial distance of 305 mm from the axis of rotation of the assembly, the two axes being mutually perpendicular. The central boss is 102 mm in outside diameter and 200 mm long and is mounted coaxially on the fixed steel pivot shaft, which is approximately 25 mm in diameter, however the precise diameter of the shaft will depend on the bearings used.

Diametrically opposite the hammer shaft are two steel counterbalance arms, each 20 mm in outside diameter and 185 mm long. These arms are screwed into the boss so that the length of 150 mm protrudes. A steel counterbalance weight is mounted on the arms so that its position can be adjusted to balance the weight of the striker and arms, as shown in Figure C.1. On one end of the central boss a 12 mm wide and 150 mm diameter aluminium alloy pulley is mounted and round this an inextensible cable is wound, one end being fixed to the pulley. The other end of the cable supports the operating weight.

The rigid frame also supports the mounting board on which the manual call point is mounted in its normal operating position by its normal fixings. The mounting board is adjustable in order to fix the required strike positions as shown in Figure C.2 and Figure C.3.

To operate the apparatus, the position of the manual call point and the mounting board is first adjusted as shown in Figure C.2 or Figure C.3 and the mounting board is then secured rigidly to the frame. The hammer assembly is then balanced carefully by adjustment of the counterbalance weight with the operating weight removed. The hammer arm is then drawn back to the horizontal position ready for release and the operating weight is reinstated. On release of the assembly the operating weight will spin the hammer and arm through an angle of  $270^\circ$  to strike the manual call point. The mass  $M$  of the operating weight to produce the required impact energy of 1,9 J equals:

$$M = \frac{0,388}{3 \cdot \pi \cdot r} ;$$

where  $r$  is the effective radius of the pulley, in metres. This equals approximately 0,55 kg for a pulley radius of 75 mm.

As the standard calls for a hammer velocity at impact of  $(1,5 \pm 0,13) \text{ m s}^{-1}$ , the mass of the hammerhead will need to be reduced by drilling the back face sufficiently to obtain this velocity. It is estimated that a head of mass of about 0,79 kg will be required to obtain the specified velocity, but this will have to be determined by trial and error.

Dimensions in millimetres

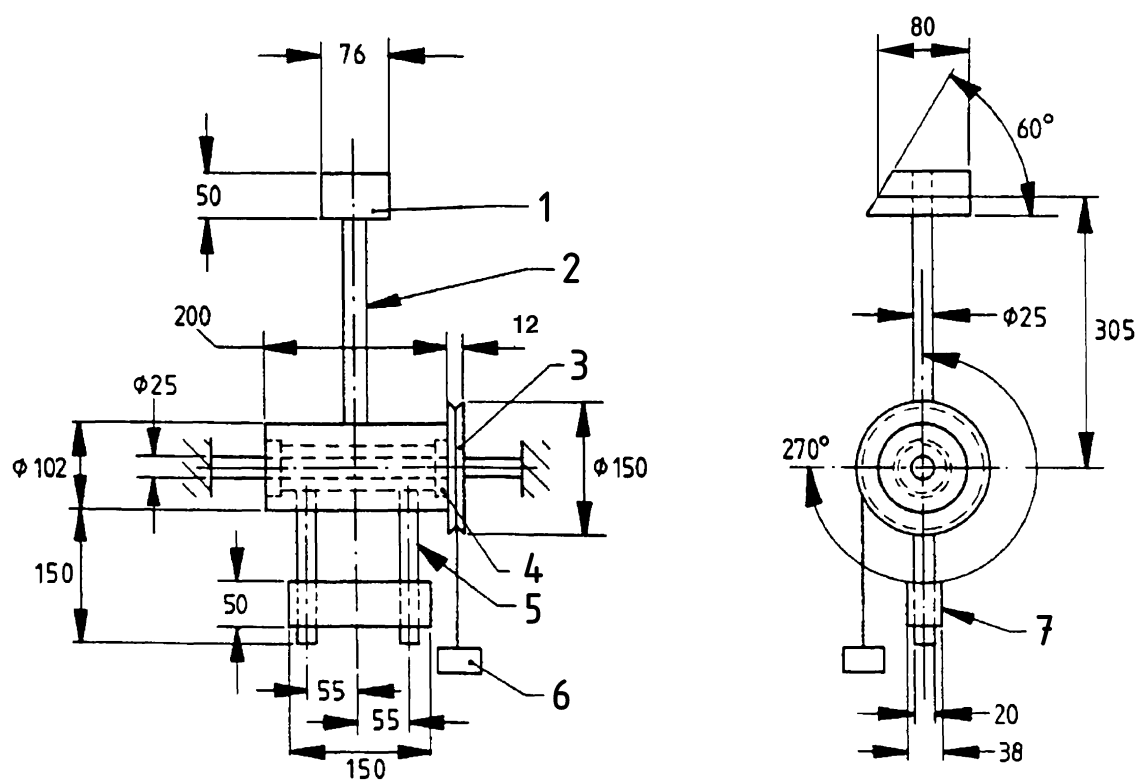

**Key**

- 1 Striker
- 2 Striker shaft
- 3 Pulley
- 4 Ball bearings
- 5 Counterbalance arms
- 6 Operating weight
- 7 Counterbalance weight

**Figure C.1 — Impact apparatus**

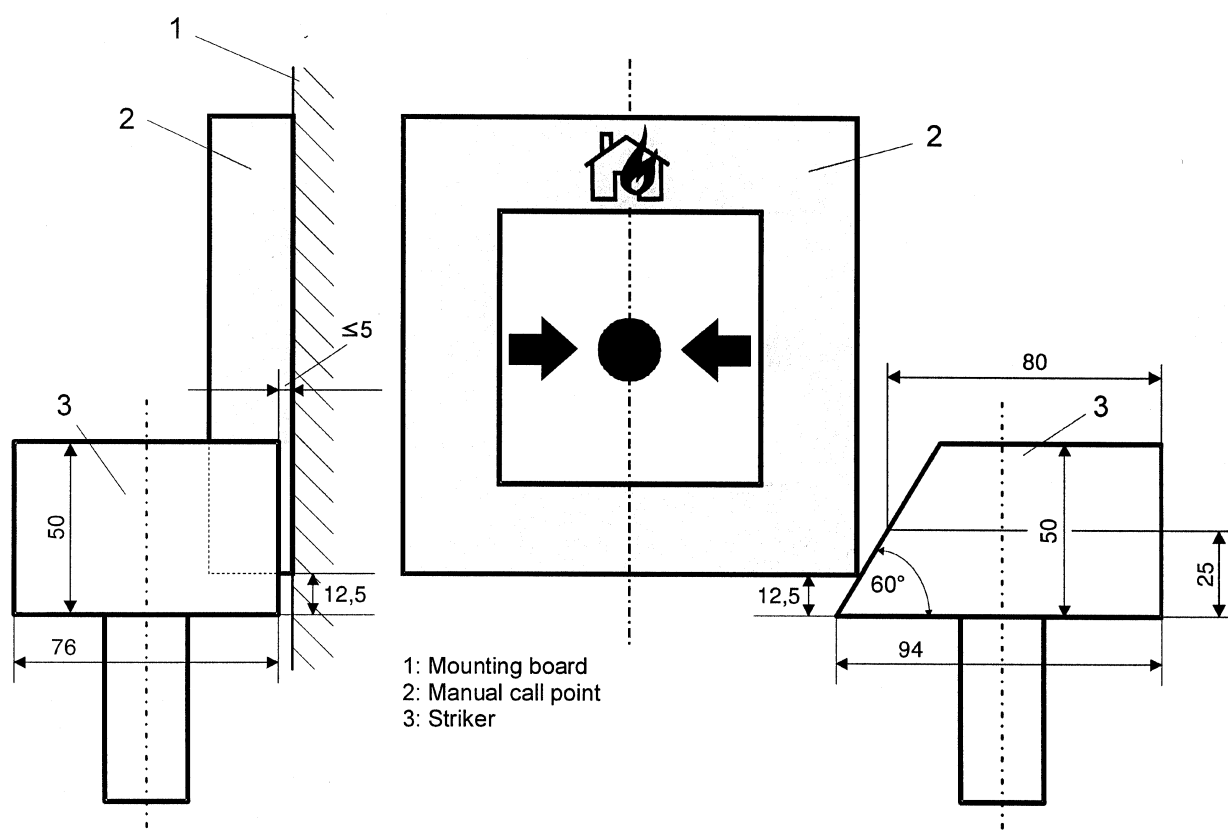

Figure C.2 — First impact, position (lower side edge)



Dimensions in millimetres

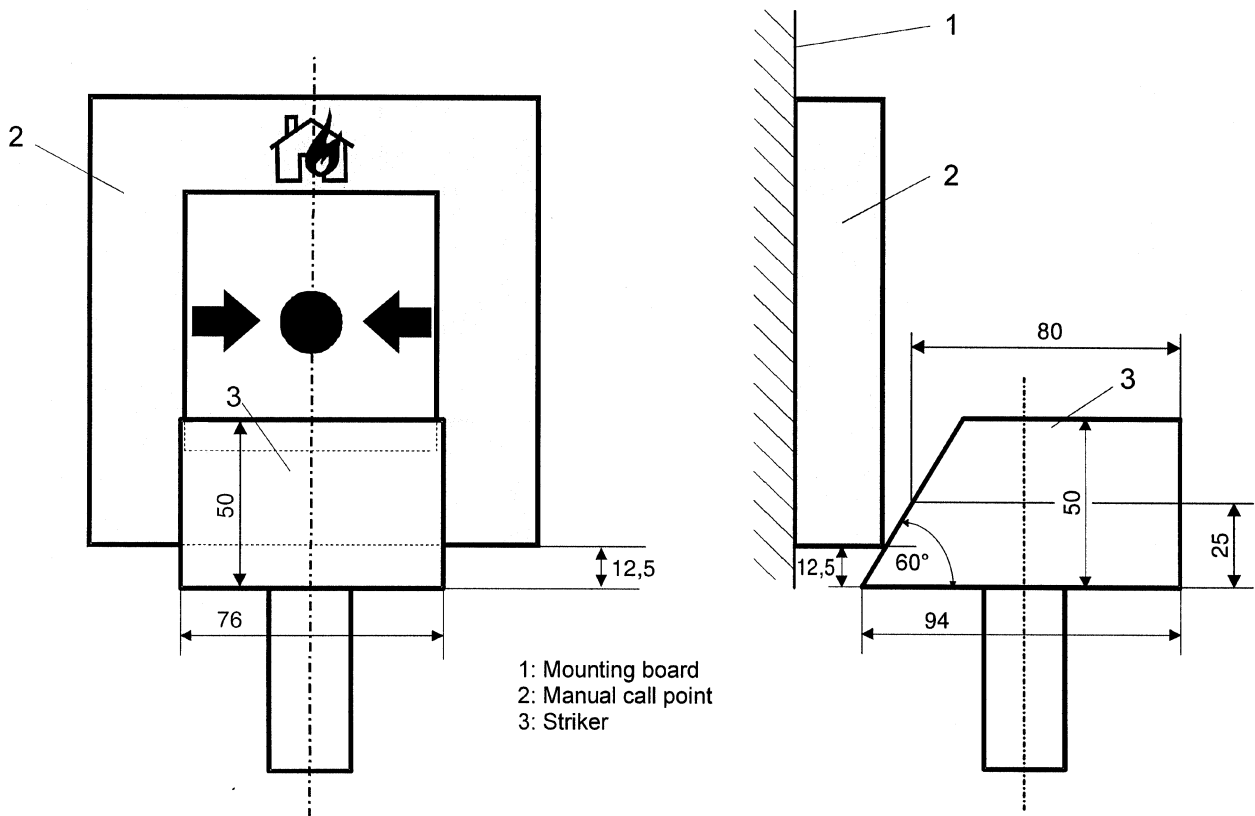

Figure C.3 — Second impact, position (lower edge of the front face)

## **Annex ZA** (informative)

### **Clauses addressing the provisions of the EU Construction Products Directive 89/106/EEC**

#### **ZA.1 Scope and relevant clauses**

This European Standard has been prepared under the mandate M/109 given to CEN by the European Commission and the European Free Trade Association.

The clauses of this European Standard, shown in this annex, meet the requirements of the mandate given under the EU Construction Products Directive (89/106/EEC).

Compliance with these clauses confers a presumption of fitness (as defined by the Construction Products Directive) of the construction product covered by this European Standard for its intended use according to Clause 1 (Scope) of this standard; reference shall be made to the information accompanying the CE marking.

**WARNING — Other requirements and other EU Directives may be applicable to the products falling within the scope of this standard.**

NOTE In addition to any specific clauses relating to dangerous substances contained in this standard, there may be other requirements applicable to the products falling within its scope (e.g. transposed European legislation and national laws, regulations and administrative provisions). These requirements need also to be complied with, when and where they apply. An informative database of European and national provisions on dangerous substances is available at the Construction web site on EUROPA (accessed through <http://europa.eu.int>).

This Annex ZA has the same scope, in relation to the products covered, as Clause 1 of this standard. This annex establishes the conditions for the CE marking of manual call points intended for the use shown below and identifies the relevant clauses applicable.

**Construction product:** Manual call points  
**Intended use:** Fire safety

**Table ZA.1 - Relevant clauses**

Essential characteristics	Clauses in this European Standard	Mandated level(s)	Notes
Nominal activation conditions / Sensitivity and Performance under fire conditions	4.3.2, 4.4, 4.7.1, 4.7.4, 5.2, 5.3	None	
Operational reliability	4.2, 4.3.1, 4.5, 4.6, 4.7.2, 4.7.3, 4.7.5, 4.8, 5.4, 5.5		
Durability of operational reliability temperature resistance	5.7, 5.8*, 5.9		* outdoor devices only
Durability of operational reliability; vibration resistance	5.14 to 5.17		
Durability of operational reliability; humidity resistance	5.10, 5.11*, 5.12, 5.19*		* outdoor devices only
Durability of operational reliability; corrosion resistance	5.11, 5.13		
Durability of operational reliability; electrical stability	5.6, 5.18 <sup>†</sup>		<sup>†</sup> devices with active electronic components only

## ZA.2 Procedures for the attestation of conformity of point smoke detectors covered by this standard

### ZA.2.1 System of attestation of conformity

The mandate requires that the attestation of conformity system to be applied shall be that shown in Table ZA.2.

**Table ZA.2 - Attestation of conformity system**

Product	Intended use	Levels or classes	Attestation of conformity system
Fire detection/Fire alarm: Manual call points	Fire safety	None	1
System 1: See CPD Annex III.2.(i), without audit-testing of samples by the notified body.			

## **ZA.2.2 Evaluation of conformity**

### **ZA.2.2.1 General**

The evaluation of conformity of the product with the requirements of this European Standard shall be demonstrated by:

- a) Tasks to be provided by the manufacturer:
  - factory production control;
  - testing of samples by the manufacturer in accordance with a prescribed test plan;
- b) Tasks to be undertaken under the responsibility of a Notified Product Certification Body:
  - type testing of the product;
  - initial inspection of the factory and factory production control;
  - periodic surveillance, assessment and approval of the factory production control.

**NOTE** The manufacturer is a natural or legal person, who places the product on the market under his own name. Normally, the manufacturer designs and manufactures the product himself. As a first alternative, he may have it designed, manufactured, assembled, packed, processed or labelled by subcontracting. As a second alternative he may assemble, pack, process, or label ready-made products.

The manufacturer shall ensure:

- that the initial type testing in accordance with this European Standard is initiated and carried out under the responsibility of a notified product certification body; and
- that the product continuously complies with the initial type testing samples, for which compliance with the European Standard in question has been verified.

He shall always retain the overall control and shall have the necessary competence to take the responsibility for the product. The manufacturer shall be fully responsible for the conformity of the product to all relevant regulatory requirements.

### **ZA.2.2.2 Type testing**

**ZA.2.2.2.1** Type testing shall be performed to demonstrate conformity with this European Standard.

Type testing of the product shall be carried out in accordance with the clauses shown in Table ZA.1, except as described in ZA.2.2.2.2 and ZA.2.2.2.3.

**ZA.2.2.2.2** Tests previously performed, such as type tests for product certification, may be taken into account providing that they were made to the same or a more rigorous test method under the same system of attestation of conformity as required by this standard on the same product or products of similar design, construction and functionality, such that the results are applicable to the product in question.

**NOTE** Same system of attestation of conformity means testing by an independent third party under the responsibility of a product certification body which is now a notified product certification body.

**ZA.2.2.2.3** Where one or more characteristics are the same for products with similar design, construction and functionality then the results of tests for these characteristics on one product may be applied to the other similar product or products.

**ZA.2.2.2.4** Test samples shall be representative of the normal production. If the test samples are prototypes, they shall be representative of the intended future production and shall be selected by the manufacturer.

**NOTE** In the case of prototypes and third party certification, this means that it is the manufacturer not the product certification body who is responsible for selecting the samples. During the initial inspection of the factory and of the factory production control (see ZA.2.2.3.4), it is verified that the type tested samples are representative of the product being produced.

**ZA.2.2.2.5** All type testing and its results shall be documented in a test report. All test reports shall be retained by the manufacturer for at least ten years after the last date of production of the product to which they relate.

### **ZA.2.2.3 Factory production control**

#### **ZA.2.2.3.1 General**

Factory production control is the permanent internal control of production exercised by the manufacturer.

All the elements, requirements and provisions adopted by the manufacturer shall be documented in a systematic manner in the form of written policies and procedures. This production control system documentation shall ensure a common understanding of conformity evaluation and enable the achievement of the required product characteristics and the effective operation of the production control system to be checked.

Factory production control therefore brings together operational techniques and all measures allowing maintenance and control of the conformity of the product with its technical specifications. Its implementation may be achieved by controls and tests on measuring equipment, raw materials and constituents, processes, machines and manufacturing equipment and finished products, including material properties in components, and by making use of the results thus obtained.

**NOTE** The FPC system may be part of a Quality Management system, e.g. in accordance with EN ISO 9001:2000.

#### **ZA.2.2.3.2 General requirements**

The manufacturer shall establish, document and maintain a FPC system to ensure that the products placed on the market conform to the stated performance characteristics and the samples subjected to type testing.

Where subcontracting takes place, the manufacturer shall retain the overall control of the product and ensure that he receives all the information that is necessary to fulfil his responsibilities according to this European Standard. If the manufacturer has part of the product designed, manufactured, assembled, packed, processed and/or labelled by subcontracting, the FPC of the subcontractor may be taken into account, where appropriate, for the product in question. The manufacturer who subcontracts all of his activities may in no circumstances pass these responsibilities on to a subcontractor.

The FPC system shall fulfil the requirements as described in the following clauses of EN ISO 9001:2000, where applicable:

- 4.2 except 4.2.1a);
- 5.1 e), 5.5.1, 5.5.2;
- Clause 6;
- 7.1 except 7.1 a), 7.2.3 c), 7.4, 7.5, 7.6;
- 8.2.3, 8.2.4, 8.3, 8.5.2.

The FPC system may be part of an existing quality management system, (e.g. in accordance with EN ISO 9001:2000), the scope of which covers the manufacture of the product.

Where a quality management system is certified in accordance with EN ISO 9001:2000 by a certification body which is now a notified certification body, the assessment reports of this quality management system may be taken into account with respect to these clauses.

### **ZA.2.2.3.3 Product-specific requirements**

The FPC system shall:

- address this European Standard; and
- ensure that the products placed on the market conform to the stated performance characteristics.

The FPC system shall include a product specific FPC or quality plan, which identifies procedures to demonstrate conformity of the product at appropriate stages, i.e.

- a) the controls and tests to be carried out prior to and/or during manufacture according to a frequency laid down; and/or
- b) the verifications and tests to be carried out on finished products according to a frequency laid down.

If the manufacturer uses only finished products, the operations under b) shall lead to an equivalent level of conformity of the product as if normal FPC had been carried out during the production.

If the manufacturer carries out parts of the production himself, the operations under b) may be reduced and partly replaced by operations under a). Generally, the more parts of the production that are carried out by the manufacturer, the more operations under b) may be replaced by operations under a). In any case the operation shall lead to an equivalent level of conformity of the product as if normal FPC had been carried out during the production.

NOTE Depending on the specific case, it can be necessary to carry out the operations referred to under a) and b), only the operations under a) or only those under b).

The operations under a) centre as much on the intermediate states of the product as on manufacturing machines and their adjustment, and measuring equipment etc. These controls and tests and their frequency shall be chosen based on product type and composition, the manufacturing process and its complexity, the sensitivity of product features to variations in manufacturing parameters etc.

The manufacturer shall establish and maintain records that provide evidence that the production has been sampled and tested. These records shall show clearly whether the production has satisfied the defined acceptance criteria and shall be available for at least three years. These records shall be available for inspection.

Where the product fails to satisfy the acceptance measures, the provisions for non-conforming products shall apply, the necessary corrective action shall immediately be taken and the products or batches not conforming shall be isolated and properly identified. Once the fault has been corrected, the test or verification in question shall be repeated.

The results of controls and tests shall be properly recorded. The product description, date of manufacture, test method adopted, test results and acceptance criteria shall be entered in the records under the signature of the person responsible for the control/test. With regard to any control result not meeting the requirements of this European Standard, the corrective measures taken to rectify the situation (e.g. a further test carried out, modification of manufacturing process, discarding or putting right of product) shall be indicated in the records.

Individual products or batches of products and the related manufacturing documentation shall be completely identifiable and retraceable.

### **ZA.2.2.3.4 Initial inspection of factory and FPC**

Initial inspection of FPC shall be carried out when the production process has been finalised and preferably in operation. The factory and FPC documentation shall be assessed to verify that the requirements of ZA.2.2.3.1 and ZA.2.2.3.2 are fulfilled.

In the assessment it shall be verified that:

- a) all resources necessary for the achievement of the product characteristics required by this European Standard are or will be available; and

- b) the FPC-procedures in accordance with the FPC-documentation are or will be implemented and followed in practice; and
- c) the product complies or will comply with the initial type testing samples, for which compliance with this European Standard has been verified.

All locations where final assembly or at least final testing of the relevant product is performed, shall be assessed to verify that the above conditions a) to c) are in place.

If the FPC system covers more than one product, production line or production process, and it is verified that the general requirements are fulfilled when assessing one product, production line or production process, then the assessment of the general requirements does not need to be repeated when assessing the FPC for another product, production line or production process.

Provided that the production process is similar, assessments previously performed in accordance with the provisions of this standard may be taken into account providing that they were made to the same system of attestation of conformity on the same product or products of similar design, construction and functionality, such that the results may be considered applicable to the product in question.

**NOTE** Same system of attestation of conformity means inspection of FPC by an independent third party under the responsibility of a product certification body which is now a notified product certification body.

All assessments and their results shall be documented in a report.

#### **ZA.2.2.3.5 Periodic surveillance of FPC**

Surveillance of the FPC shall be undertaken at least once a year.

The surveillance of the FPC shall include a review of the quality plan(s) and production processes(s) for each product to determine if any changes have been made since the last assessment or surveillance and the significance of any changes shall be assessed.

Checks shall be made to ensure that the quality plans are still correctly implemented and that the production equipment is still correctly maintained and calibrated.

The records of tests and measurement made during the production process and to finished products shall be reviewed to ensure that the values obtained still correspond with those values for the samples submitted to type testing and that the correct actions have been taken for non-compliant devices.

The surveillance of the FPC may be carried out as part of a surveillance or reassessment of a Quality Management system (e.g. in accordance with EN ISO 9001:2000).

#### **ZA.2.2.4 Procedure for modifications**

If modifications are made to the product, production process or FPC system that could affect any of the product characteristics required by this standard, then all characteristics covered by the clauses shown in Table ZA.1, which may be changed by the modification, shall be subject to type testing or engineering evaluation, except as described in ZA.2.2.2.2 and ZA.2.2.2.3. Where relevant, a re-assessment of the factory and of the FPC system shall be performed for those aspects which may be affected by the modification.

All assessments and their results shall be documented in a report.

### **ZA.3 CE Marking and labelling and accompanying documentation**

The manufacturer or his authorised representative established within the EEA is responsible for the affixing of the CE marking. The CE-marking symbol (in accordance with Directive 93/68/EEC) shall be placed on the product and be accompanied by the number of the EC certificate of conformity and the Notified Body number. If the Notified Body number is included as part of the number of the EC certificate of conformity, then the number of the EC certificate of conformity is sufficient.

The CE marking symbol shall in addition be shown on the accompanying commercial documentation supplemented by:

- a) the identification number of the Notified Product Certification Body;
- b) the name or identifying mark and registered address of the manufacturer;
- c) the last two digits of the year in which the marking was affixed;
- d) the number of the EC certificate of conformity;
- e) reference to this European standard (EN 54-11);
- f) the description of the construction product (Manual call points for fire detection and fire alarm systems for buildings);
- g) the type/model designation of the product;
- h) other information required by 4.2 and/or 4.8 or a reference to a document, which shall be uniquely identifiable and available from the manufacturer, containing this information.

Where the product exceeds the minimum performance levels stated in this standard, and where the manufacturer so desires, the CE marking may be accompanied by an indication of the parameter(s) concerned and the actual test result(s).

Figure ZA.1 shows an example of the information to be given on the accompanying commercial documentation.

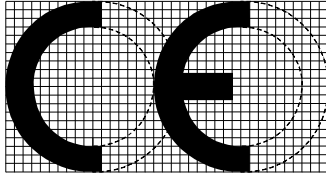
 0123
<b>AnyCo Ltd</b> , P.O. Box 21, B1050  <b>06</b> 0123 – CPD – 001
<b>EN 54-11</b> Manual call points ABC 123 Technical data: see Doc.123/2006 held by the manufacturer.

**Figure ZA.1 — Example of CE marking information on the accompanying commercial documentation**

#### **ZA.4 EC certificate and declaration of conformity**

The manufacturer, or his authorised representative established in the EEA, shall prepare and retain a declaration of conformity, which authorises the affixing of the CE marking. This declaration shall include:



- the name and address of the manufacturer, or his authorised representative established in the EEA, and the place of production;

NOTE 1 The manufacturer may also be the person responsible for placing the product onto the EEA market, if he takes responsibility for CE marking.

- the description of the construction product (i.e. manual call points for fire detection and fire alarm systems for buildings), and a copy of the information accompanying the CE marking;

NOTE 2 Where some of the information required for the Declaration is already given in the CE marking information, it does not need to be repeated.

- type/model designation of the product;
- provisions to which the product conforms (i.e. Annex ZA of this EN);
- any particular conditions applicable to the use of the product (if necessary);
- name and address (or identification number) of the Notified Product Certification Body;
- name of and position held by the person empowered to sign the declaration on behalf of the manufacturer or of his authorized representative.

The declaration shall contain a certificate of conformity with the following information:

- name and address of the Notified Product Certification Body;
- certificate number;
- name and address of the manufacturer, or his authorised representative established in the EEA;
- description of the construction product (i.e. manual call points for fire detection and fire alarm systems for buildings);
- type/model designation of the product;
- provisions to which the product conforms (i.e. Annex ZA of this EN);
- any particular conditions applicable to the use of the product (if necessary);
- any conditions of validity of the certificate, where applicable;
- name of and position held by the person empowered to sign the certificate.

The above mentioned declaration and certificate shall be presented (if requested) in the language or languages accepted in the Member State in which the product is to be used.

## Bibliography

EN ISO 9001:2000, *Quality management systems - Requirements (ISO 9001:2000)*



---

---

## BSI — British Standards Institution

BSI is the independent national body responsible for preparing British Standards. It presents the UK view on standards in Europe and at the international level. It is incorporated by Royal Charter.

### Revisions

British Standards are updated by amendment or revision. Users of British Standards should make sure that they possess the latest amendments or editions.

It is the constant aim of BSI to improve the quality of our products and services. We would be grateful if anyone finding an inaccuracy or ambiguity while using this British Standard would inform the Secretary of the technical committee responsible, the identity of which can be found on the inside front cover. Tel: +44 (0)20 8996 9000. Fax: +44 (0)20 8996 7400.

BSI offers members an individual updating service called PLUS which ensures that subscribers automatically receive the latest editions of standards.

### Buying standards

Orders for all BSI, international and foreign standards publications should be addressed to Customer Services. Tel: +44 (0)20 8996 9001. Fax: +44 (0)20 8996 7001. Email: [orders@bsi-global.com](mailto:orders@bsi-global.com). Standards are also available from the BSI website at <http://www.bsi-global.com>.

In response to orders for international standards, it is BSI policy to supply the BSI implementation of those that have been published as British Standards, unless otherwise requested.

### Information on standards

BSI provides a wide range of information on national, European and international standards through its Library and its Technical Help to Exporters Service. Various BSI electronic information services are also available which give details on all its products and services. Contact the Information Centre. Tel: +44 (0)20 8996 7111. Fax: +44 (0)20 8996 7048. Email: [info@bsi-global.com](mailto:info@bsi-global.com).

Subscribing members of BSI are kept up to date with standards developments and receive substantial discounts on the purchase price of standards. For details of these and other benefits contact Membership Administration. Tel: +44 (0)20 8996 7002. Fax: +44 (0)20 8996 7001. Email: [membership@bsi-global.com](mailto:membership@bsi-global.com).

Information regarding online access to British Standards via British Standards Online can be found at <http://www.bsi-global.com/bsonline>.

Further information about BSI is available on the BSI website at <http://www.bsi-global.com>.

### Copyright

Copyright subsists in all BSI publications. BSI also holds the copyright, in the UK, of the publications of the international standardization bodies. Except as permitted under the Copyright, Designs and Patents Act 1988 no extract may be reproduced, stored in a retrieval system or transmitted in any form or by any means – electronic, photocopying, recording or otherwise – without prior written permission from BSI.

This does not preclude the free use, in the course of implementing the standard, of necessary details such as symbols, and size, type or grade designations. If these details are to be used for any other purpose than implementation then the prior written permission of BSI must be obtained.

Details and advice can be obtained from the Copyright & Licensing Manager. Tel: +44 (0)20 8996 7070. Fax: +44 (0)20 8996 7553. Email: [copyright@bsi-global.com](mailto:copyright@bsi-global.com).